

# DIAGRAMS: TS / Inverter

## *TS Load Control with Inverter*

v01

### Abstract:

Two diagrams are provided showing how load control can be safely used with inverters. The first diagram is applicable to all inverters. The second diagram is applicable to Morningstar SureSine inverters (and possibly 3rd party inverters with remote ON/OFF contacts). **Note that in these diagrams, the TriStar Load Controller can be replaced with any Morningstar controller with Load Control functionality.**

## Diagram #1 (applicable with all inverters)

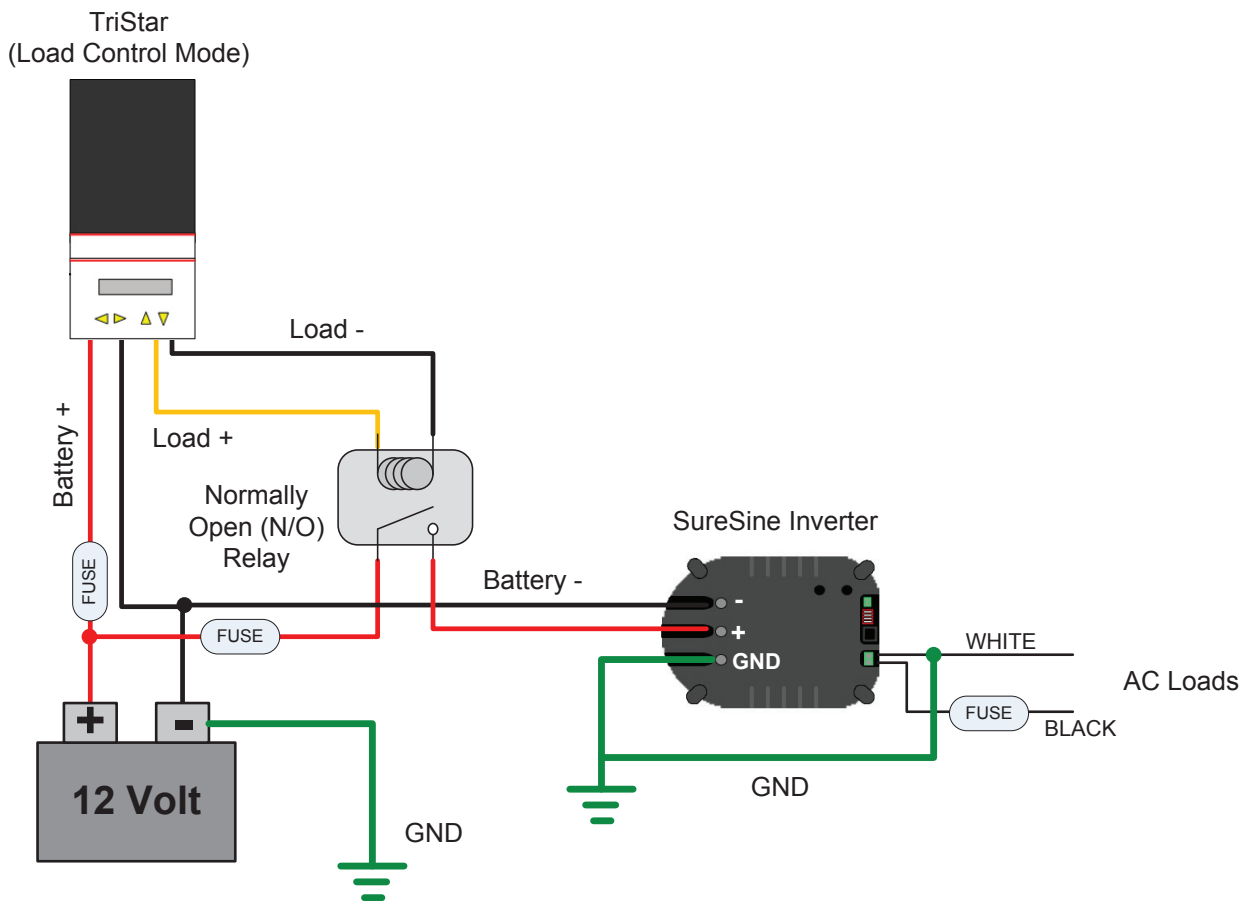

**IMPORTANT:** This is not intended to be a complete system diagram; fusing, disconnects, and grounding should comply with local electric codes.

### Notes:

- The Inverter cannot be connected directly to the Load +/- terminals of the TriStar Load Controller. Instead, it is connected directly to the battery bank.
- In order to use the TriStar Load Control with the inverter connected directly to the battery bank, a Relay must be used.
- A Relay is connected in series between the battery bank and inverter DC input. The Relay is controlled by the TriStar Load Controller. Via the Relay, the TS is able to control when the inverter is ON or OFF.
- Ensure that the Relay is rated to handle the full DC surge current drawn by the inverter.
- For detailed installation information, please consult the respective product manuals (TriStar, Inverter).

## Diagram #2 (applicable with SI-300)

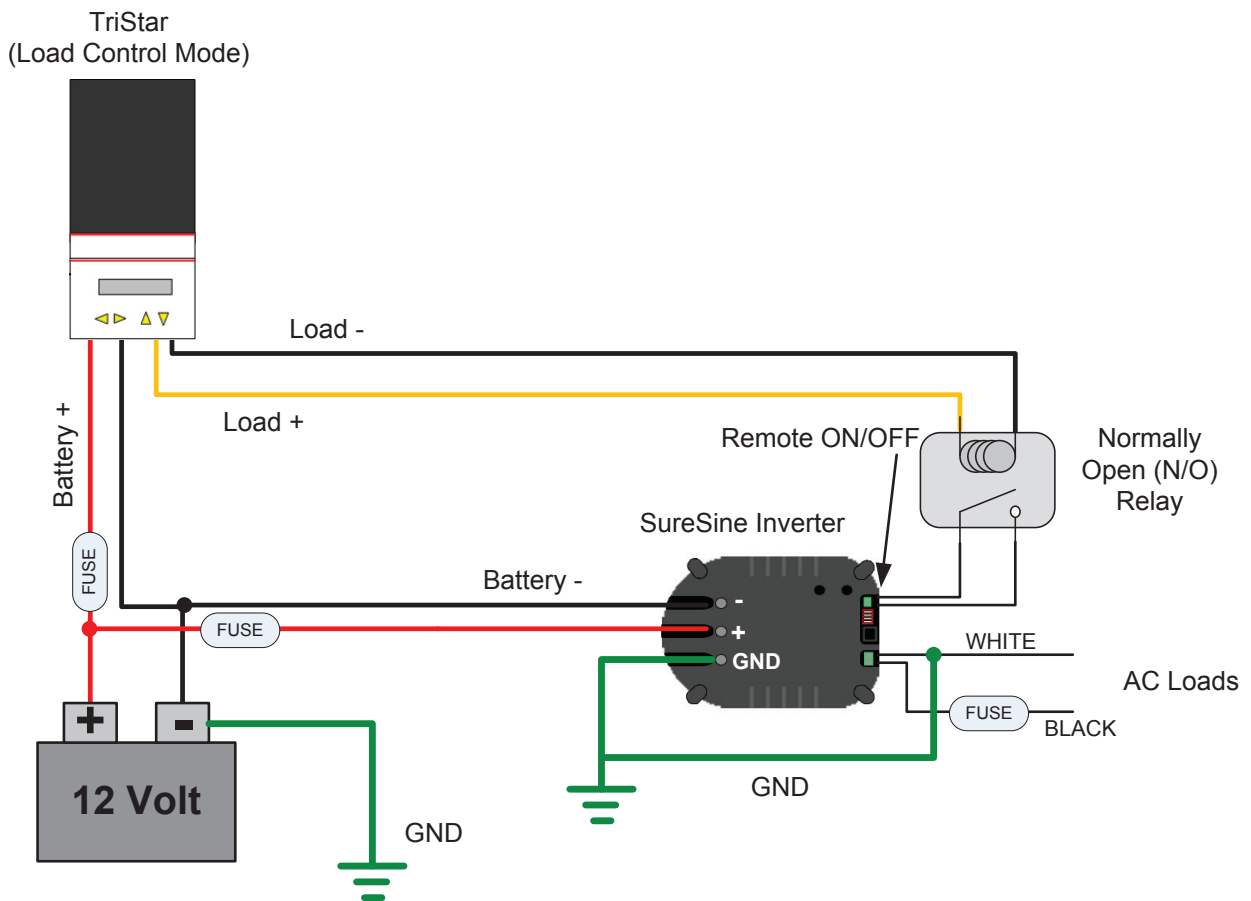

**IMPORTANT:** This is not intended to be a complete system diagram; fusing, disconnects, and grounding should comply with local electric codes.

### Notes:

- The Inverter cannot be connected directly to the Load +/- terminals of the TriStar Load Controller. Instead, it is connected directly to the battery bank.
- In order to use the TriStar Load Control with the inverter connected directly to the battery bank, a Relay must be used.
- A Relay is used as a contactor for the Remote ON/OFF terminal present on the SureSine 300. The TriStar controller when the Relay turns ON/OFF. Via the Relay connected to the Remote terminal, the SureSine AC output is turned ON/OFF.
- For detailed installation information, please consult the respective product manuals (TriStar, SureSine).

© 2013 Morningstar Corporation. All rights reserved.