

Morningstar Product Connectivity Manual

Networking & Communications

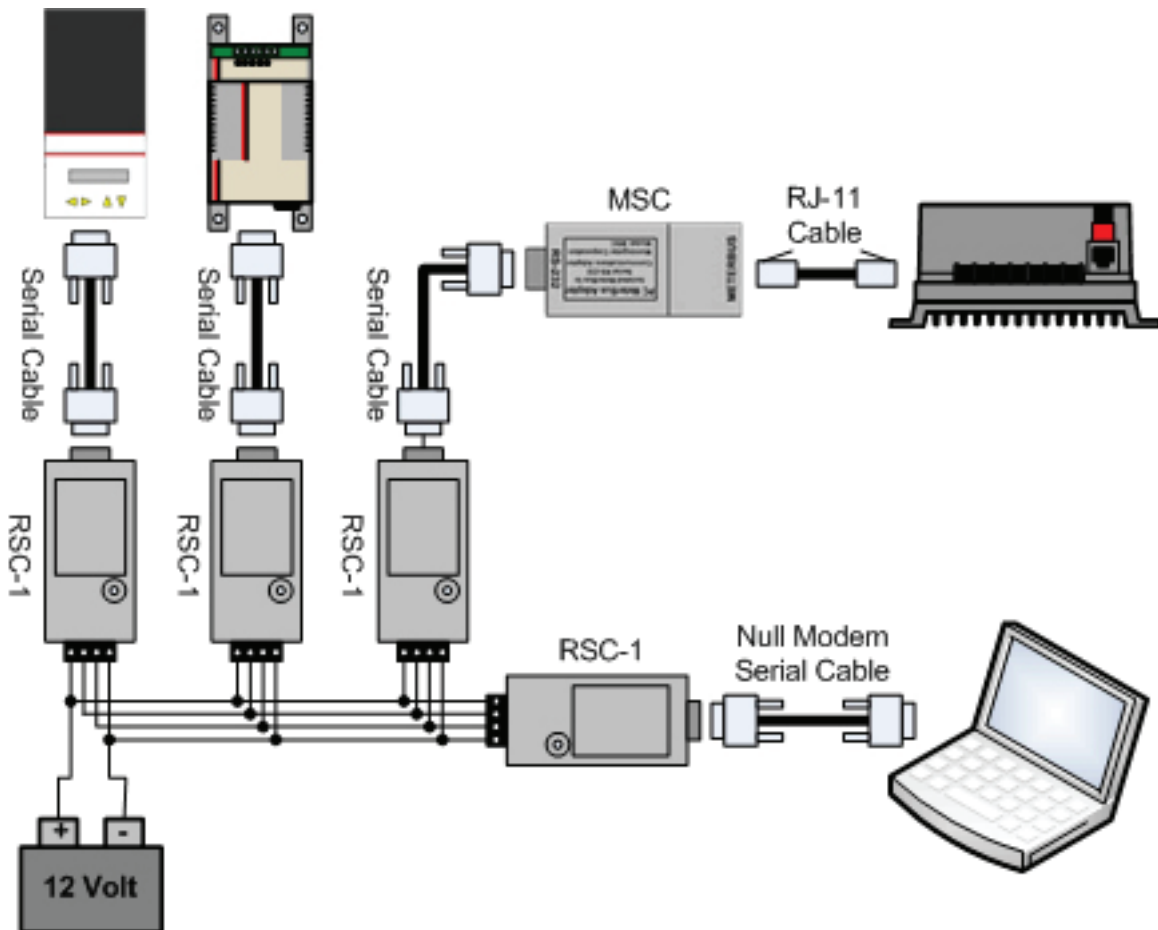

04 March 2024



www.morningstarcorp.com

Contents

1.0 Introduction

- 1.1 Communications Protocols
- 1.2 Communications Interfaces
- 1.3 RS-232 vs. USB

2.0 Networking Hardware

- 2.1 Morningstar Equipment
- 2.2 Other Equipment

3.0 MeterBus™ Networks

- 3.1 Overview
- 3.2 Networking Rules
- 3.3 Example Networks
- 3.4 Setup Your MeterBus™ Network

4.0 MODBUS™ Networks

- 4.1 Overview
- 4.2 Local Connections
- 4.3 Remote Connections

5.0 MSView™

- 5.1 Overview
- 5.2 Installation
- 5.3 Establishing A Connection
- 5.4 Creating a New Display
- 5.5 Setup Wizards

6.0 Firmware Updates

- 6.1 OverView
- 6.2 Uploading Firmware with MSLoad™
- 6.3 Uploading Firmware with LiveView
- 6.4 Uploading Firmware with Local Meter Display

6.5 Uploading Firmware with BlueTooth Mobile Utility App

7.0 Web site Hosting via HTTP

8.0 SNMP

9.0 Data Logging

10.0 Network Security

11.0 Troubleshooting & Misc.

Appendix I - TSMPT & EMC-1 Networking

- I. Introduction
- II. Connect to LAN
- III. Remote Access
- IV. Multi-Controller Networking
- V. Additional Info

Appendix II - Advanced System Example

General Safety Information:

- Only minimal voltages/currents are present in communications circuits, however, it is always necessary to exercise caution when working with electronic circuits. Please observe caution while performing any installation/maintenance outlined in this document.
- Do not allow any electronic components to be exposed to water *at any time*.
- Read installation and configuration procedures thoroughly before proceeding with physical connections.

The following symbols are used throughout this document to indicate potentially dangerous conditions or mark important safety instructions.



WARNING: Indicates a potentially dangerous condition. Use extreme caution when performing this task.



CAUTION: Indicates a critical procedure for safe and proper operation of the components in use.



NOTE: Indicates a procedure or function that is important for the safe and proper operation of the system.

1.0 Introduction

Thank you for choosing Morningstar for your PV control system needs. Morningstar products offer a wide range of networking, logging, data transfer, and custom setting capabilities. Please review this document carefully and become familiar with all the networking/communication options Morningstar products have to offer.

1.1 Communications Protocols

Various protocols are used by Morningstar products to either communicate between Morningstar devices, or with a PC/other 3rd party hardware. A brief description of these protocols follow:

1.1.1 Morningstar MeterBus™

MeterBus™ Protocol is Morningstar's proprietary messaging structure for communication between Morningstar products. This protocol is used for communications between controllers and meters, controllers and Relay Drivers, and for other inter-product data transfer.

Morningstar products supporting this protocol feature RJ-11 ports. Physical connections between MeterBus™ devices are made using standard 4 or 6 conductor phone cords with RJ-11 connectors. MeterBus™ networks have a 15 device capability, a simple RJ-11 interface, and are easy to setup and maintain.

Meter Hubs are used to network MeterBus™ capable devices. Each network device is assigned a unique MeterBus™ ID. In these networks, some devices supply power to the network, while others receive power from the network.

For more information into the capabilities of MeterBus™ and how to setup a MeterBus™ network, please refer to Section 3.

1.1.2 MODBUS™

MODBUS™ is an open and license-free protocol that is widely regarded as the de facto standard in the industrial automation industry. There is an abundance of software and equipment available that directly support MODBUS™. Additionally, sample source code for a variety of platforms is readily available online. Morningstar's free MSView™ PC software uses MODBUS™ for all communications.

MODBUS™ does not rely on any one physical communication interface; it works the same on all physical interfaces. Each device is configured to be a master or a slave. Masters always 'poll' or start conversations on the network and either slaves or other masters can respond. Two modes of MODBUS™ transmission exist, ASCII and Remote Terminal Unit (RTU).



IMPORTANT: Morningstar products are MODBUS™ RTU devices.

For more information into the capabilities of MODBUS™, please refer to Section 4.

1.1.3 MODBUS TCP/IP™

The MODBUS™ protocol can also be used over Internet Protocol (IP) via an Ethernet connection. MODBUS™ data over IP is identical to MODBUS™ data over serial RS-232, however, it is embedded in data packets characteristic of IP.

MODBUS TCP/IP™ uses an Ethernet (RJ-45) connection and is supported by all Morningstar products with an Ethernet port. It allows the user to connect to the Ethernet enabled unit using the MSView™ software package and view real-time system data, log system data, and program custom charging setpoints.

Morningstar products without an Ethernet port (but with another communications port) require the EMC-1 Ethernet to MeterBus™ Adapter or a MODBUS™ Ethernet to Serial converter serving as a bridge between MODBUS IP™ and serial MODBUS™ in order to be connected to an Ethernet network. See Sections 2.1.5 and 2.2.14.

1.1.4 HTTP

HyperText Transfer Protocol is the most common communications protocol used for transmitting data over the Internet. Ethernet capable Morningstar controllers feature HTTP compatibility, enabling it to host web pages that display controller settings, real-time system data, logged historical data, and system status. The GenStar also includes HTTP web pages for control commands, custom settings and firmware updates.

1.1.5 SMTP

Simple Mail Transfer Protocol (SMTP) is used by Ethernet enabled Morningstar controllers to deliver e-mail alerts and regular status updates of the system. See Section 8 for more information on the ability to provide e-mail/sms alerts via SMTP.

1.1.6 SNMP

Simple Network Management Protocol (SNMP) is an Internet standard protocol that is used to manage and monitor devices on an IP network. It is typically supported by devices found in IT infrastructures, such as servers, modems, routers, printers, workstations, and other network components.

Using the defined communication standards and management topology, SNMP allows for a simple and convenient way to view and modify the status of critical system components on a private Local Area Network (LAN) or across a Wide Area Network (WAN), if so desired. See Section 8 for more information on how SNMP is implemented with Morningstar controllers.

1.2 Communications Interfaces

The following table outlines the various communications interfaces found on Morningstar products. (Each dot represents one interface.)

Product	RJ-11	RS-232	EIA-485	USB	Ethernet	MS-CAN
PC MeterBus™ Adapter (MSC)	•	•				
Meterbus To EIA-485 Adaptor (MRC-1)	•		•			
RS-232 / RS-485 Adapter (RSC-1)		•	•			
USB MeterBus™ Adapter (UMC-1)	•			• (USB-A)		
Ethernet MeterBus™ Converter (EMC-1)	•	• ¹			•	
Meter Hub (HUB-1)	••••••					
Relay Driver (RD-1)	••	•				
Remote Meter (RM-1)	•					
TriStar Meter (TS-M-2)	••					
TriStar Remote Meter (TS-RM-2)	••					
TriStar Meter 600V (TS-M-2-600V)	••					
SunSaver Duo (SSD-25)	•					
SunSaver MPPT (SS-MPPT-15L)	•					
ProStar (PS-xx..) (3rd Generation only)	•					
ProStar MPPT (PS-MPPT-xx..)	•					
TriStar (TS-xx)	•	•				
TriStar MPPT 150V (TS-MPPT-xx)	•	• ²	• ^{2,3}		•	
TriStar MPPT 600V (TS-MPPT-60-600V)	•	• ²	• ²		•	
Suresine (SI-300-xxxV) Classic	•					
SureSine (SI-150 & 300-xxxV)			•			••
SureSine (SI-700 to 2500-xxxV)			•	• (USB-A)	•	••
GenStar MPPT (GS-MPPT-xx)		• ²	• ²	• (USB-C)	•	••
ReadyBMS						•• ⁴

Table 1. Morningstar Device Communication Interfaces

¹ RS-232 serial connection required for products that include an RS-232 port. The EMC-1 included Y-cable is required to draw power from the RJ-11 port while communicating via the RS-232 port. An EMC-1 connection to RD-1 requires a MeterBus™ connection from a device that can supply power. See Table 2 in section 3.2.2.

² RS-232 and EIA-485 connections share the same internal hardware; therefore, **only one interface can be used at a time.**

³ EIA-485 and Ethernet ports are available only for TriStar MPPT 60A model (TS-MPPT-60). The TS-MPPT-30 and TS-MPPT-45 models do not include the EIA-485 or Ethernet ports.

⁴ The ReadyBMS supports other 3rd party CAN interfaces that are required by the battery BMS to which it is connected.

1.3 RS-232 vs. USB

Many Morningstar products use the RS-232 interface as standard for communication with a PC. Some have inquired as to why a USB interface was not used instead. The following describes some of the problems with USB and why RS-232 has, for the most part, been chosen to be the Morningstar standard:

- USB cannot go long distances (maximum range without repeaters/hubs is 5 meters)
- USB requires more expensive hardware
- USB requires more software / RS-232 requires no driver support
- USB isn't easily opto-isolated (opto-isolation helps protect devices from transient power surges)
- USB is less immune to electromagnetic interference (EMI)
- USB is less popular as an industrial standard

As a convenience for those who are using a PC or laptop that does not include a RS-232 port Morningstar has introduced the UMC-1 USB MeterBus™ Adapter (Section 2.1.4). This is especially useful as a simple way to make a temporary connection for programming custom settings, firmware updates or on-site visits. There are also 3rd party USB to RS-232 devices available on the market (Section 2.2.12)

2.0 Networking Hardware

There are many pieces of networking hardware. The following is a description of the most common hardware used to network Morningstar devices.

2.1 Morningstar Equipment

2.1.1 PC MeterBus™ Adapter (MSC)



Figure 1. Morningstar PC MeterBus™ Adapter (model: MSC)

The PC Meterbus™ Adapter (model: MSC) converts the Morningstar MeterBus™ RJ-11 electrical interface to a standard RS-232 interface which allows MODBUS™ communication between a PC and a Morningstar charge controller or inverter**. Controllers with *only* an RJ-11 port require the MSC to program custom charging setpoints or log data using Morningstar's MSView™ PC software. The MSC can also be used with any 3rd party MODBUS™ capable hardware to communicate with the Morningstar unit.

** controllers or inverters with a MeterBus™ connection that do not have a serial port or other communications port

2.1.2 RS-232 / EIA-485 Adapter (RSC-1)

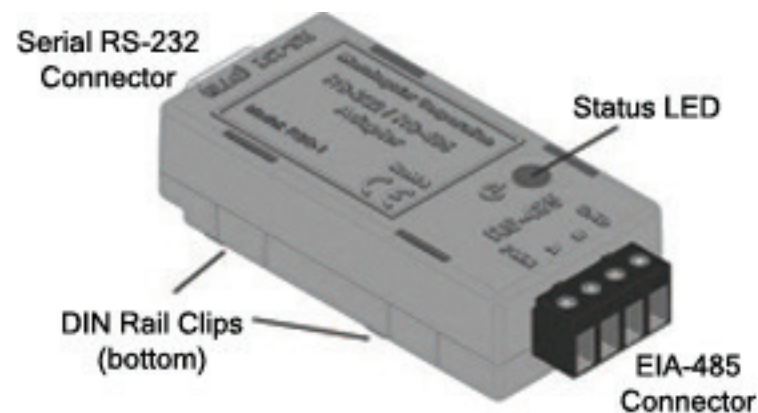

Figure 2. Morningstar RS-232 / RS-485 Adapter (model:RSC-1)

The RSC-1 adapter provides the ability to network RS-232 serial devices over an EIA-485 bus using MODBUS™ protocol. A null modem cable is used to connect a PC to the RSC-1, while a straight-through serial cable is used to connect a Morningstar device to the RSC-1.

The RSC-1 requires an external power source. Input voltage to the adapter should be between 8-16V, therefore, it may be powered by a 12 Volt battery. Use a DC-DC converter for 24V, 36V, and 48V system batteries.



CAUTION: Tapping off individual batteries in a bank can cause an imbalanced battery bank. Always use a DC-DC converter if the nominal system voltage is greater than 12V.

2.1.3 MeterBus™ to EIA-485 Adapter (MRC-1)

The MRC-1 adapter provides the ability to network Morningstar MeterBus™ RJ-11 serial devices to an EIA-485 bus using the MODBUS™ protocol. The EIA-485 bus can include RSC-1 connected devices, Morningstar devices that have a built-in EIA-485 port and 3rd party EIA-485 devices.

The MRC-1 is capable of supplying isolated 12VDC power from the MeterBus to an EIA-485 network, eliminating the need for an external 12VDC bus power source in many cases. However, there are power limitations. The MRC-1 power switch must be turned on in order to provide the +12VDC power.

When the MRC-1 power switch is off, it must be powered externally as with an RSC-1. Input voltage to the adapter should be between 8-16V, therefore, it may be powered by a 12 Volt battery. Use a DC-DC converter for 24V, 36V, and 48V system batteries.

CAUTION: Tapping off individual batteries in a bank can cause an imbalanced battery bank. Always use a DC-DC converter if the nominal system voltage is greater than 12V.

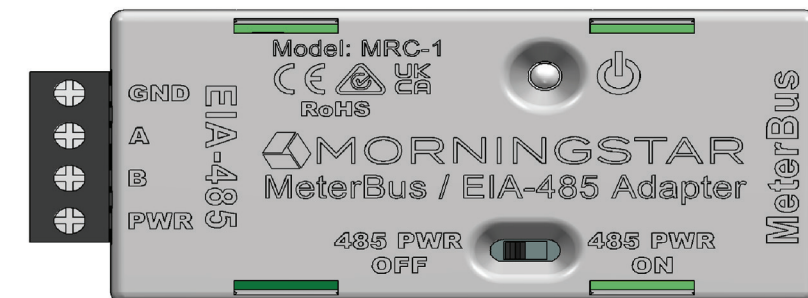

Figure 3. Morningstar MeterBus™ to EIA-485 Adapter (model:MRC-1)

2.1.4 USB MeterBus™ Adapter (UMC-1)



Figure 4. Morningstar Meter Hub (model:UMC-1)

The USB MeterBus™ Adapter (model: UMC-1) converts the Morningstar MeterBus™ RJ-11 electrical interface to a standard USB 2.0 interface which allows MODBUS™ communication between a PC and a Morningstar charge controller or inverter**. Controllers with *only* an RJ-11 port can use the UMC-1 to program custom charging setpoints, log data using Morningstar's MSView™ PC software or perform Firmware updates with Morningstar's MSLoad™ Software. The UMC-1 can also be used with any 3rd party MODBUS™ capable hardware to communicate with the Morningstar unit.

** controllers or inverters with a MeterBus™ connection that do not have a serial port or other communications port

2.1.5 Ethernet MeterBus™ Converter (EMC-1)

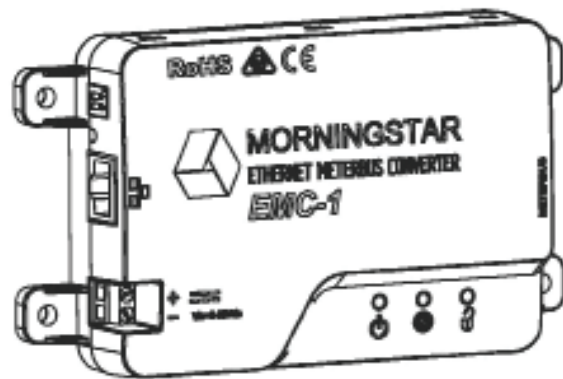

Figure 5. Morningstar Ethernet MeterBus™ Converter (model: EMC-1)

The EMC-1 is an Ethernet to Meterbus™ converter that creates a Serial-to-Ethernet connection to a Morningstar charge controller or inverter (Morningstar Device). The connected device needs to have a MeterBus™ (RJ-11) port.

The EMC-1 acts as an Ethernet gateway that serves MODBUS IP, local Web pages, SNMP and,

for future use, Web Monitoring Services. Ethernet connectivity allows users to remotely collect information about their off-grid PV system. Ethernet networks also include Local Area Networks (LANs) and Internet communications.

The EMC-1 supports the following communication capabilities with a Morningstar Device:

- Morningstar LiveView™ Internet Web monitoring and Network settings configurations.
- Monitoring, logging and custom programming using Morningstar MSView™ PC software
- SNMP polling of dynamic solar values through 3rd-party Network Management Software (NMS)

2.1.6 Meter Hub (HUB-1)



Figure 6. Morningstar Meter Hub (model:HUB-1)

The Meter Hub allows for easy scalability of a MeterBus™ network by providing five extra RJ-11 MeterBus™ ports. Ports 1-4 are electrically isolated from Power Output and Power Input Ports A & B. Each draws operating power from the device connected to the Port. Up to four Meter Hubs can be linked on the same MeterBus™ network. Refer to Section 3.2 for more information regarding proper use of Meter Hubs.

2.2 Other Equipment

In addition to Morningstar equipment, other 3rd party networking supplies will usually be needed. The following is a description of products which may be needed for proper networking. These products will be mentioned throughout this manual; please take the time to familiarize yourself with them.

For some, a specific company/product recommendation is made. **Recommendations made are only a guideline for the user. Morningstar makes no guarantee that these products will interface properly with Morningstar units. Please do all necessary research into compatibility before making a purchase.**

2.2.1 Serial (DB-25) / Serial (DB-9) Adapter

There are two different types of serial connectors. One has 25 pins and the other (found on Morningstar devices) has 9 pins. Adapters are available to convert 25 pin serial to 9 pin serial. One may be necessary, for example, if your computer has a 25 pin serial connection and you want to directly connect to a TriStar with a 9 pin connection. These adapters usually do not come attached to the end of a serial cable; a cable is needed in addition to the adapter.



Figure 7. DB-25 to DB-9 Adapter

2.2.2 Straight-Through Serial Cable

Straight-through serial cables connect a Data Terminal Equipment (DTE) device to a Data Communications Equipment (DCE) device by matching Tx pins, Rx pins, CTS pins, and RTS pins between devices, thus the name straight-through cable. Both ends of the cable terminate in DB-9 connectors. These can either be regular-style (cylindrical) or ribbon cable (flat); either are suitable for use. When using a TriStar controller, a *ribbon-style* cable is needed for proper fit under the cover lid; a regular-style cable will not fit. www.blackbox.com has low-profile ribbon cables for purchase.



Figure 8a. Regular-style serial cable



Figure 8b. Ribbon-style serial cable

NOTE: Male/female end connections will vary. Please be sure you purchase a cable with the proper connectors to attach your devices.

2.2.3 Null Modem (Crossover) Cable

A null modem serial cable allows two DTE devices to communicate directly without a DCE device, such as a modem. The null modem cable connects the Rx (receive) pins to opposing Tx (transmit) pins and Clear-to-Send (CTS) pins to their opposing Request-to-Send (RTS) pins. Both ends of the cable terminate in DB-9 connectors.



Figure 9. Null Modem Serial Cable



NOTE: Both straight-through and null modem serial cables will vary in color, length, and male/female end connections. They may look identical on the outside, but internally they are different.

2.2.4 USB-A to USB-C Data Cable

Universal Serial Bus (USB) is an industry standard for data transfer and power for USB devices. The USB Type-C connector is the newest USB interface and commonly used with android phones and other devices. A USB-A to USB-C cable that supports data transfer is required in order to make a PC connection to a GenStar or other future Morningstar products that have a USB-C port.



Figure 10. USB-A to USB-C Data Cable

2.2.5 USB-A to USB-A Male to Male Data Cable

USB-A to USB-A male to male cables are used to make a communications connection between devices that both have a USB-A female port. A USB-A to USB-A male to male cable that supports data transfer is required in order to make a PC connection to newer SureSine inverters or other future Morningstar products that have a USB-A port that supports communications. Note that the EcoBoost includes a USB port for charging and not for data.



Figure 11. USB-A to USB-A cable

2.2.6 USB-A to USB-B Data Cable

USB-A to USB-B cables are commonly used for communications between a PC and printers and other types of peripheral devices. Morningstar's USB MeterBus™ Adapter (model: UMC-1) includes a USB-A to USB-B cable but it can be replaced with a longer cable if required.



Figure 12. USB-A to USB-B cable

2.2.7 Ethernet Cable

Category 5 and 6 (Cat5, Cat5E, Cat6, Cat6A) cables have four twisted pairs of conductors terminating in an RJ-45 connector. The conductors can either be solid or stranded. Solid conductors are less expensive, however, they do not provide the flexibility and resiliency of stranded conductors. These cables are most commonly used in LAN/WAN 100Mbit/s networks and also with MS-CAN communications between Morningstar equipment.



Figure 13. Standard Ethernet Cable

2.2.8 Ethernet Crossover Cable

Similar to a null modem cable, an Ethernet crossover cable allows two devices that are normally connected through a hub or a router to communicate directly. When these devices are connected through a hub or router, the crossover is done internally, making a crossover cable unnecessary.



Figure 14. Ethernet Crossover Cable



NOTE: Both standard and crossover Ethernet cables will vary in color and length. They may look identical on the outside, but internally they are different.

2.2.9 RJ-45 CAN Terminator Plug

An RJ-45 CAN Terminator plug is placed at the beginning and end of a CAN Bus network. CAN Bus terminator plugs include a 120 ohm resistor between the CANL and CANH wires. The terminator is designed to match the AC impedance of the cable and hence minimize signal reflections, and power losses.

Morningstar products that include CAN Bus communications ports include a terminator plug. For any BMS-battery side or other 3rd party CANBus termination requirement, refer to the manufacturer's documentation.

2.2.10 RJ-11 Cable

RJ-11 cable is the standard cable used in telephone wiring. The wire must be either 4 or 6 (commonly referred to as RJ-12) conductor and terminate in RJ-11 connectors. Morningstar products that require an RJ-11 cable will ship with one in-box. The provided cable should always be used.



Figure 15. RJ-11 (telephone) Cable

2.2.11 Serial / EIA-485 Converter (3rd Party)

As an alternative to the Morningstar RSC-1, other companies offer Serial / EIA-485 converters. These converters, like the RSC-1 provide the ability to network serial devices over an EIA-485 bus using the MODBUS™ protocol. Converters can either be port powered or externally powered, opto-isolated or non-isolated. For the converter to work properly with Morningstar products, it must be **externally powered and non-isolated**. This allows the converter to supply the necessary power to opto-isolated serial ports. Note: The Morningstar RSC-1 adapter is highly recommended for this application. It has been specifically designed to work with Morningstar products. Some 3rd party adapters have been known to either cause problems on the network, or need minor pin modifications to work properly.



CAUTION: Example: If a converter needs 12V external power in a 24V system, a DC-DC converter should be used. Tapping off individual batteries can cause an imbalanced battery bank.



Figure 16. Serial RS-232 / EIA-485 Converter

Recommended: Morningstar's RS-232 / EIA-485 Adapter (RSC-1) (See Subsection 2.1.2)

2.2.12 USB / Serial Adapter Cable

A USB / Serial adapter cable will convert a USB connection on your PC to a DB-9 serial connection, compatible with Morningstar devices. **Note:** Most of these adapter cables come with drivers which must be installed to create a Virtual COM port (VCOM). This allows the computer to view a USB port as a serial port. More can be found on VCOMs in Subsection 5.3.1. **It has been reported that some USB to Serial adapters will not work with either the MSC or our controllers. This is usually due to the adapter output voltage being below the RS-232 electrical specification. Section 11 Troubleshooting explains this further.**

Note: For controllers which do not include an RS-232 port the **UMC-1 USB to MeterBus™ Adapter** is highly recommended and a more practical solution than using the **MSC PC MeterBus™ Adapter** with a 3rd party USB / Serial Adapter.



Figure 17. Tripp Lite USB / Serial DB-9 Adapter

Recommended: Tripp Lite U209-000-R (shown above)

2.2.13 USB Hub

A USB hub allows multiple USB devices to use the same local USB port on your PC. There are two types of hubs, bus-powered and self-powered. Bus-powered hubs draw all their power from the PC's USB port and require devices connected to them to share this power. This often limits the number and types of USB devices which can be connected to the hub. Self-powered, however, uses an external power source to supply full power to every port on the hub.



Figure 18. Aaxeon USB Hub

Recommended: Aaxeon USB-HUB4K (shown above)

2.2.14 Ethernet / Serial Converter (supporting MODBUS™)

As an alternative to the Morningstar EMC-1 other companies offer Ethernet / Serial converters which can allow the Ethernet port on your PC, router, or hub to connect to the DB-9 serial port on Morningstar devices. (Often these converters will have an EIA-485 connection for use with an EIA-485 network.) It provides a gateway between MODBUS IP™ and MODBUS™ serial networks. This converter can allow for direct PC to controller/inverter connection, or connection via LAN/WAN/Internet. Software usually comes with the converter and allows you to assign it an appropriate IP address. **Important: The converter must be capable of MODBUS TCP/IP™ support.**

Note: The Morningstar **EMC-1 Ethernet MeterBus™ Converter** is highly recommended for this application. It has been specifically designed to work with Morningstar products without requiring an MSC adapter. The EMC-1 also provides LiveView HTML pages which are not available through 3rd party products. Some 3rd party adapters have been known to either cause problems on the network, or need minor pin modifications to work properly.



Figure 19a. Moxa Ethernet / Serial Converter (A)



Figure 19b. B&B Elec. Converter (B)

Recommended: (A) MOXA MGate MB3180/3280/3480 (please refer to Section 11) or
(B) B&B Electronics MES1A

2.2.15 Ethernet Router

Ethernet routers allow you to establish a LAN, which can then be connected to the Internet. Information sent from a PC or device will have a destination address. It travels to the router, where the router looks up the destination address and forwards it to the appropriate PC or device on the local network. This equipment can be used to connect multiple controllers and a PC over a network and allow them to communicate using the MODBUS IP™ protocol.



Figure 20. RuggedCom Ethernet Router

Recommended: RuggedCom RuggedRouter RX1000 (shown above)



NOTE: Routers vary greatly in cost. The RuggedRouter RX1000 is a high-end industrial router. If a less expensive, non-industrial router is desired, Linksys provides reliable alternatives.

2.2.16 Cellular Modem/ Cellular Router (supporting MODBUS™)

Wireless cellular modems and routers can connect through an existing cell network. Several mobile standards exist. Global System for Mobile communications (GSM) is used extensively on the global cell market. Newer standards are also available such as UMTS, CDMA or EV-DO. Verify your cellular service provider uses a mobile standard compatible with the cellular modem you purchase. **Important: This equipment must be MODBUS™ compatible.**



Figure 21a. Moxa Cellular Modem (A)



Figure 21b. Digi Cellular Router

Recommended: (A) MOXA OnCell Quad-band GSM/GPRS 850/900/1800/1900 MHz
(B) Digi Connect WAN Family of products (one model shown above)



NOTE: Please consult your wireless data provider for information regarding if/how your cellular modem connection will suit your needs and applicable fees.

2.2.17 Point-to-Point Radio (supporting MODBUS™)

These radio systems are used to connect remotely to a device 10-25km away in the field. This type of connection requires a base radio at the PC and a field radio at the device site. Data is transmitted wirelessly over the connection without the need for external services or fees. These devices often operate in the ISM band so unlicensed operations are typically permitted. Some systems can have multiple field units, however, the base radio can only communicate with them one at a time.

Advanced security encryption is recommended when using these devices. Data transmitted wirelessly is much easier to intercept than data over a wired connection. Proper encryption ensures your data is protected.

Important: This equipment must be MODBUS™ compatible.



Figure 22. B&B Electronics P-to-P Radio Modem

Recommended: B&B Elec. Zlinx Industrial Radio Modem ZP24D-192RM-MR (shown above)

2.2.18 Programmable Logic Controller (PLC) - MODBUS™ supported

Programmable Logic Controllers can be used as master devices on EIA-485 networks. When multiple controllers are connected over an EIA-485 bus, they are not able to communicate with each other. However, a master device, such as a PLC or PC, is able to poll each controller and retrieve information.

Morningstar controllers are MODBUS™ Remote Terminal Unit (RTU) slave devices and can be polled by RTUs and PLCs with MODBUS™ capability. SCADA (System Control And Data Acquisition) systems often use PLCs to poll RTU devices for data.

PLCs vary greatly in their features and pricing, however, you must be sure the PLC is **MODBUS™ compatible** for it to communicate with Morningstar products.

3.0 MeterBus™ Networking

3.1 Overview

The MeterBus™ Protocol is Morningstar's proprietary messaging structure for communication between Morningstar products. This protocol is used for communications between controllers or inverters and meters, controllers and Relay Drivers. Morningstar products supporting this protocol feature RJ-11 ports.

Setup a MeterBus™ network to:

- display net system data for multiple controller systems¹
- communicate with a TriStar Meter 2 or TriStar Remote Meter 2²
- communicate with a Relay Driver

¹ A Morningstar MeterBus™ Hub (HUB-1) and TriStar Digital Meter 2 (TS-M-2) or TriStar Remote Meter 2 (TS-RM-2) are required.

² TriStar Meters are only compatible with TriStar and TriStar MPPT controllers at the time of this publication.

3.2 Networking Rules

3.2.1 General

- Up to four Meter Hubs can be linked together, accommodating a maximum of 15 Morningstar devices on a single MeterBus™ network.
- A maximum of two meters (of any model) are allowed on a single MeterBus™ network.
- Each device in the network must be programmed with a unique MeterBus™ ID.
- Ports 1-4 on the Meter Hub provide no output power and are isolated from all other ports.
- Ports A & B are not isolated from each other.
- A TriStar Meter 2 is required for MeterBus™ network data display.
- The ProStar and ProStar MPPT local meter will continue to function on a MeterBus™ network but will not display network data.
- The RM-1 cannot be used on a MeterBus™ network.

3.2.2 Power Management

The Meter Hub electrically isolates devices that supply power to the MeterBus™, preventing grounding problems.

Table 2 below lists all Morningstar Devices that can be networked using the Meter Hub. Table 2 is divided into two columns. Column A lists all devices that supply power to the MeterBus™ Network. All devices listed in column B require power from the MeterBus™ Network to operate. It is important to understand the power requirements of each device connected to a MeterBus™ network. Devices that require power from the network must be connected to devices that supply power.

(A) Supplies Power	(B) Requires Power
SunSaver Duo	Remote Meter (RM-1)
SunSaver MPPT	TriStar Digital Meter 2 (TS-M-2)
ProStar Gen 3	TriStar Remote Meter 2 (TS-RM-2)
ProStar MPPT	Relay Driver
TriStar	MeterBus™ Adapters & Converters for MODBUS™/MeterBus™ (see section 4.3.6)
TriStar MPPT (150V & 600V)	
Suresine Classic	

Table 2. Morningstar Device MeterBus™ Power Specifications

- One device from Table 2. Column A must be connected to Input Power Port B of the Meter Hub. Ports A and B are not isolated from each other, therefore, when Input Power Port B is energized, Output Power Port A provides power to its device.
- To link multiple hubs, Output Power Port A is connected to Input Power Port B on the next hub, thereby providing power.
- A maximum of three devices can be powered off a single device from Column A.
- Only one device from Table 2, column A may be connected to each port on the Meter Hub.
- Table 2, Column B devices cannot be the only device connected to ports 1-4 (these ports do not provide output power).
- To supply power to a device from Column B, you must connect a device from Column A to the device from Column B, and then connect that device (B) to a port on the Meter Hub. Example Network #2 shows how to correctly achieve this.

3.3 Example Networks

3.3.1 Example #1 - Small Network

A typical small network is shown in Figure 23 below. The TriStar connected to Port B is electrically isolated from the TriStar on Port 1. This prevents differences in ground potential, disconnected grounds, or differing system voltage to damage the network equipment or controllers. The TS Remote Meter connected to Output Power Port A is powered from the TriStar connected to Port B and is also isolated from Port 1.

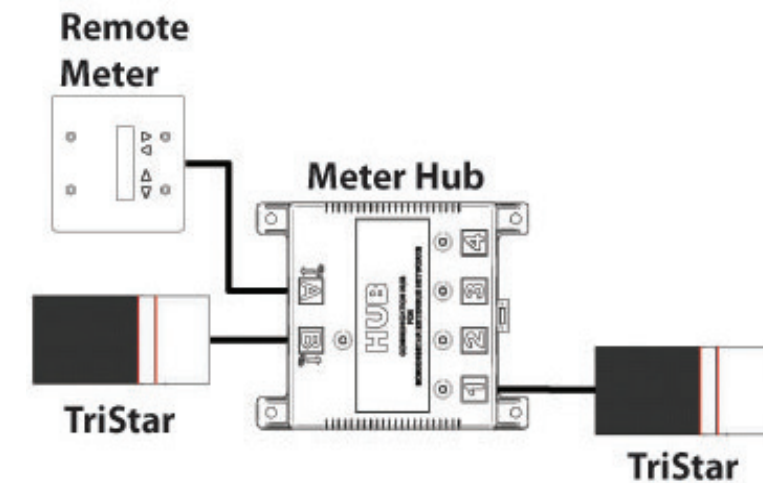

Figure 23. Morningstar MeterBus™ Small Network Diagram

3.3.2 Example #2 - Medium-Sized Network

A typical medium-sized network can be seen in Figure 24. This network is comprised of three TriStars, two TS Meters, one Relay Driver, and one Meter Hub. As with the small network, the TS Remote Meter is powered via the TriStar on Input Power Port B. **Remember:** Only two meters are allowed on a single MeterBus™ network. Notice that the Relay Driver is a device that requires power, yet is connected to Port 1 (a port that does not supply output power). A TriStar is used to power the RD-1 in this case.

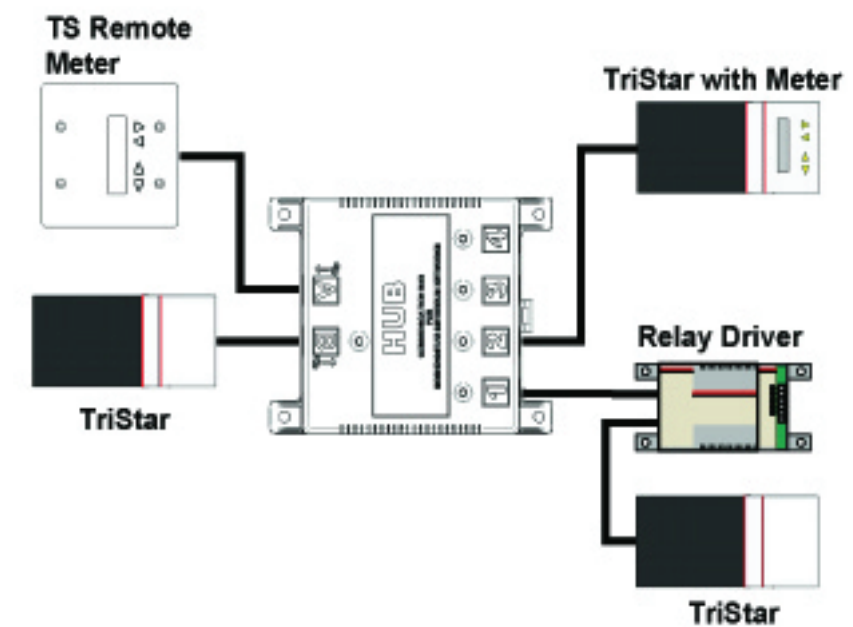

Figure 24. Morningstar MeterBus™ Medium-Sized Network Diagram

3.3.3 Example #3 - RD-1 Polling Network

A Relay Driver used in conjunction with a Meter Hub allows the Relay Driver to poll multiple controllers and trigger alarms based upon specific controller inputs. For example, the RD-1 could trigger an alarm for overcurrent on one of the controllers, while simultaneously triggering an alarm for LVD on one of the other controllers. Note that the Relay Driver is connected to Output Power Port A because it does not supply its own power to the MeterBus™ network.

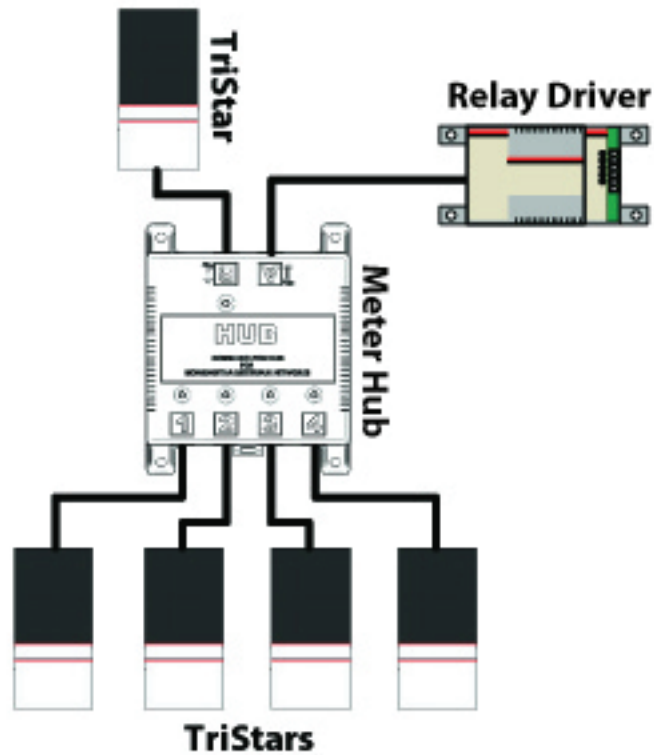

Figure 25. Morningstar MeterBus™ RD-1 Polling Network Diagram

3.3.4 Example #4 - Large, Multiple Hub Network 1

Figure 26 illustrates a large MeterBus™ network making use of multiple Meter Hubs. The two hubs are linked using the *Link Out / Link In* Ports A & B, respectively. Each hub expands the number of MeterBus™ connections to the network. Notice that the TriStar powering the hubs can only accommodate a maximum of three (labeled 1-3) devices that require power (two hubs and one TS Remote Meter in the diagram below). **Remember:** A maximum of four Hubs may be linked on one MeterBus™ network, accommodating up to 15 MeterBus™ devices. Regardless of how many Hubs are used, all networking rules concerning power management still apply.

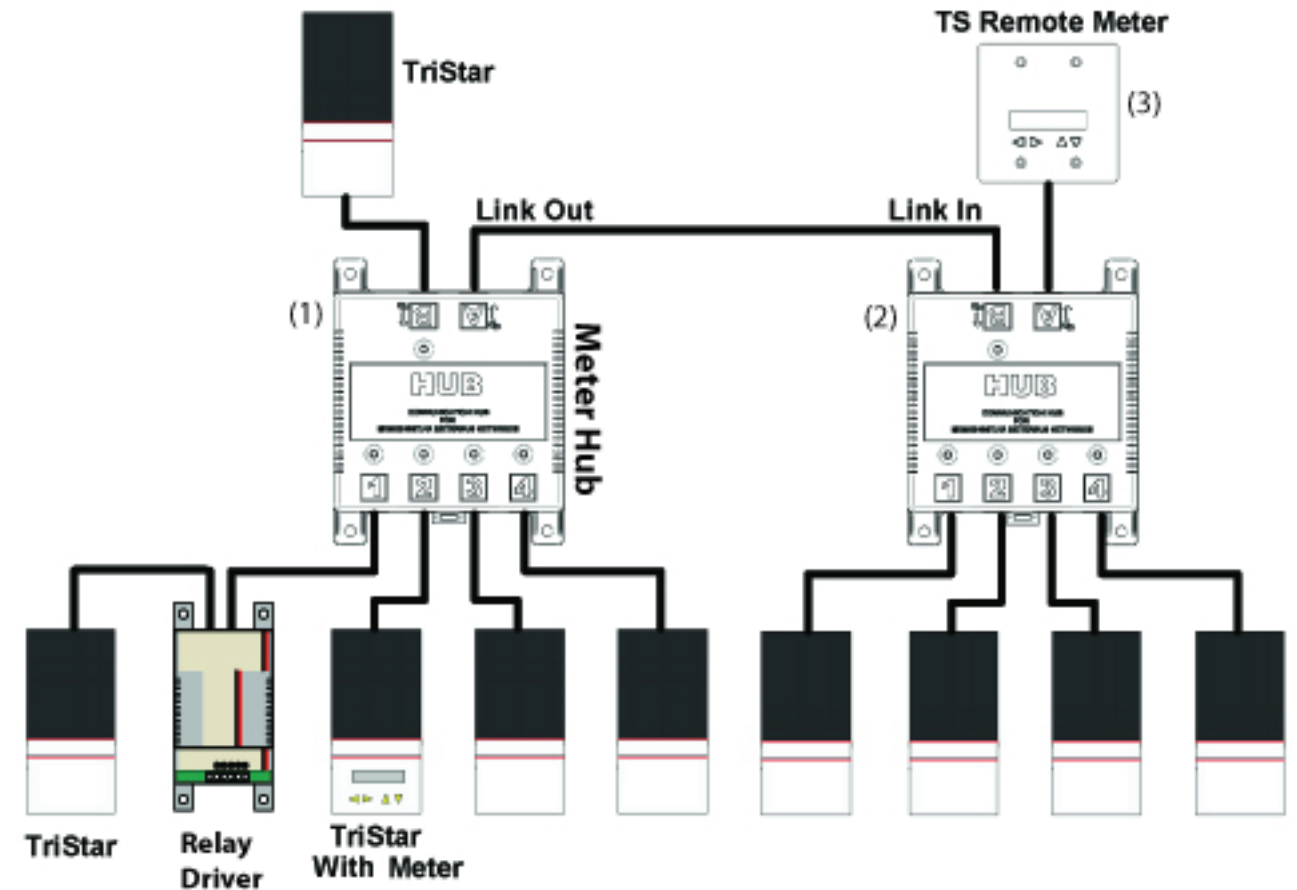

Figure 26. Morningstar MeterBus™ Large, Multiple Hub Network Diagram 1

3.3.5 Example #5 - Large, Multiple Hub Network 2

Device power requirements will sometimes call for a network setup as illustrated in Figure 27. This multiple hub network connects hubs in a different manner than in Example #4. Since the TriStar (with Meter) can only power up to three devices (Meter, Hub, Relay Driver - denoted 1 through 3 in the diagram), the output link of the Relay Driver cannot be connected to the input of the second hub. Another unit that provides power (i.e. TriStar) is used to power the second hub and TS Remote Meter. To network the two hubs, the output link of the Relay Driver (3) is connected to one of the isolated ports on the second hub.

Figure 27 illustrates only one example of the way these 14 units can be networked together.

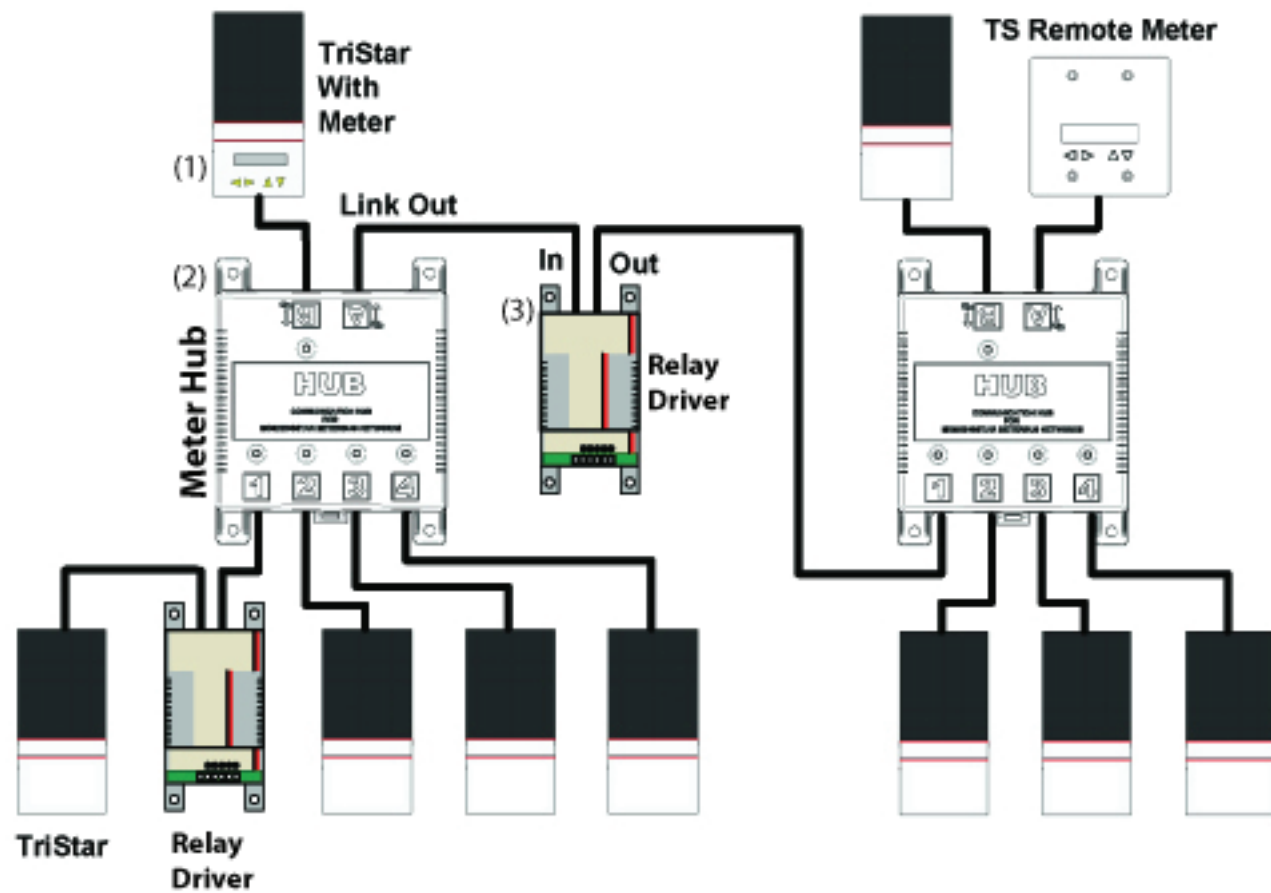

Figure 27. Morningstar MeterBus™ Large, Multiple Hub Network Diagram 2

NOTE: All networks illustrated above use TriStars to power the network, however, any controller/inverter listed in Table 2. Column A will do the same.

3.4 Setup Your MeterBus™ Network

3.4.1 Layout and Connections

Before you begin physically constructing your MeterBus™ network, make sure you have the proper cables, connectors, adapters, and mounting hardware. It is best to organize exactly where devices will be mounted, cables will be run, etc before physically mounting the equipment. This ensures enough space for the system and allows for an organized, clean installation.

WARNING: Do not route COM cables in the same conduit as power cables.

Be sure to observe the MeterBus™ Networking Rules as outlined in Subsection 3.2.

3.4.2 Addressing

To enable devices on the network to communicate with each other, each one must be assigned a unique MeterBus™ ID. Only 15 devices are allowed on a single network, therefore, the range of acceptable MeterBus™ IDs is 1 to 15. There are two manners in which you can assign these addresses: using a TriStar Meter, local ProStar or ProStar MPPT meter or by using a PC.

NOTE: Morningstar recommends using a TS Meter 2/TS Remote Meter 2 for addressing TriStars and TriStar MPPT controllers or the local ProStar and ProStar MPPT meters due to its simplicity and speed.

3.4.2.1 TriStar Meter (TriStar/TS-MPPT only) or ProStar/PS-MPPT Local Meters

A TriStar Meter is capable of assigning an MeterBus™ ID to each TriStar & TS-MPPT device on the MeterBus™ network before they are connected. Attach the meter to the device using the TS-M-2 / TS-RM-2 manual and meter map to set the desired MeterBus™ ID. The MeterBus™ ID of ProStar & PS-MPPT controllers that have local meters can also be assigned as indicated in the manual and meter map.

Make sure no two devices have the same ID on the network. Two devices with the same address will cause communications problems on the network and unexpected behavior will result.

3.4.2.2 PC Connection (all devices)

A PC can be used to individually connect and assign MeterBus™ IDs to Morningstar products. This can be accomplished with Morningstar's MSView™ software package or with the LiveView HTML Network Settings with an Ethernet connection. For information on how to install and configure devices using MSView™, please refer to Section 5. For information on network settings in LiveView please refer to Appendix I and the applicable TriStar MPPT or EMC-1 manual.

All devices on the network, except for the Meter Hub and TS Meters, need to be programmed individually. Connect to the network devices one by one and use the MSView™ software to assign IDs that are unique on the network. MSView™'s Setup Wizard and the LiveView Network Settings tab are an invaluable tools for this task.

Make sure no two devices have the same ID on the network. Two devices with the same address will cause communications problems on the network and unexpected behavior will result.

3.4.3 TriStar Meter Verification

Use a network Meter (TS-M-2 or TS-RM-2) to view data for each Tristar and TriStar MPPT controller on the network. Make sure that all TriStar and TriStar MPPT controllers are accessible through the meter and that aggregate meter data is an accurate account of the TriStar/TriStar MPPT system as a whole.

3.4.4 TriStar Meter Verification

Use a network Meter (TS-M-2 or TS-RM-2) to view data for each TS/TS-MPPT on the network. Make sure that all network devices are accessible through the meter and that aggregate meter data is an accurate account of the TS/TS-MPPT units in the system as a whole.

4.0 MODBUS™ Networking

4.1 Overview

MODBUS™ is an open and free communications protocol widely used in industrial automation. It allows for networking of up to 247 devices on a single data link.

Setup a MODBUS™ network to:

- program custom charge settings with MSView™ PC software
- view real-time data with MSView™ PC software
- log real-time data with MSView™ PC software
- update controller firmware
- assign functions to a Relay Driver

4.2 Local Connections

Local connections are between a PC and device where direct MODBUS™ is used without the need for Internet Protocol (IP) or cellular networks.

 **NOTE:** Do NOT use a NULL modem cable for the following connections unless explicitly stated.

4.2.1 Serial / Serial (RS-232 / RS-232)

Serial connections made through RS-232 connectors require a male DB-9 to female DB-9 cable. Connect the male DB-9 to the Morningstar product and the female DB-9 to the COM port on your computer. Figure 28 below illustrates a proper connection.

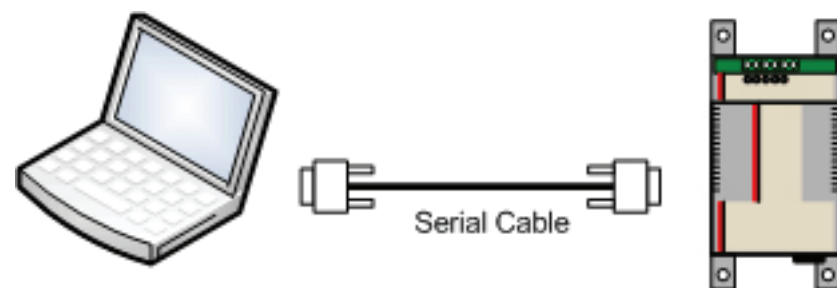

Figure 28. RS-232 / RS-232 Connection Diagram

Once connected, please refer to Section 5 on how to make Local Connections in MSView™.

4.2.2 USB / Serial (USB / RS-232)

To connect the serial RS-232 connection on a Morningstar product to a USB port on a PC, a USB to Serial adapter cable is needed. See Subsection 2.2.12 for a info and a recommendation of a compatible USB to Serial adapter. Figure 29 below illustrates a proper connection.

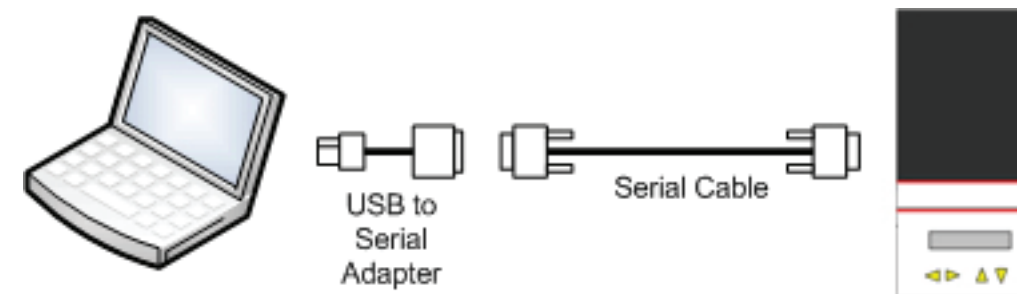

Figure 29. USB / Serial Connection Diagram

Once connected, please refer to Section 5 on how to make Local Connections in MSView™.

4.2.3 Serial (RS-232) / RJ-11

The ProStar MPPT, ProStar Gen 3, SunSaver Duo, SunSaver MPPT, and Suresine Classic do not have RS-232 connections, however, they are programmed to use their RJ-11 connections for MODBUS™ serial communications. To convert the RJ-11 to RS-232 a Morningstar PC MeterBus™ Adapter is needed (sold separately). Connect your computer's serial port to the RS-232 connection on the adapter, then connect the adapter and the Morningstar device's RJ-11 ports with a 4 or 6 conductor phone cable. Figure 30, below, illustrates a proper connection.

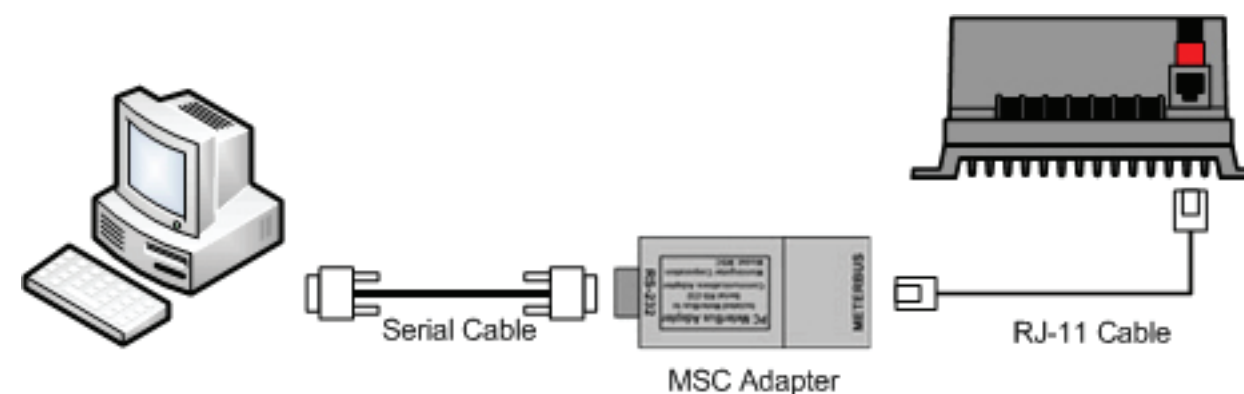

Figure 30. Serial / RJ-11 Connection Diagram

Once connected, please refer to Section 5 on how to make Local Connections in MSView™.

4.2.4 Serial (USB) / RJ-11

If your computer does not have a serial (DB-9) port and the device you are attempting to connect to has only an RJ-11 port, the simplest solution is to use Morningstar's USB MeterBus™ Adapter (model: UMC-1) which will provide a USB Serial to RJ-11 connection with a single adapter. Figure 31, below, illustrates the proper connection.

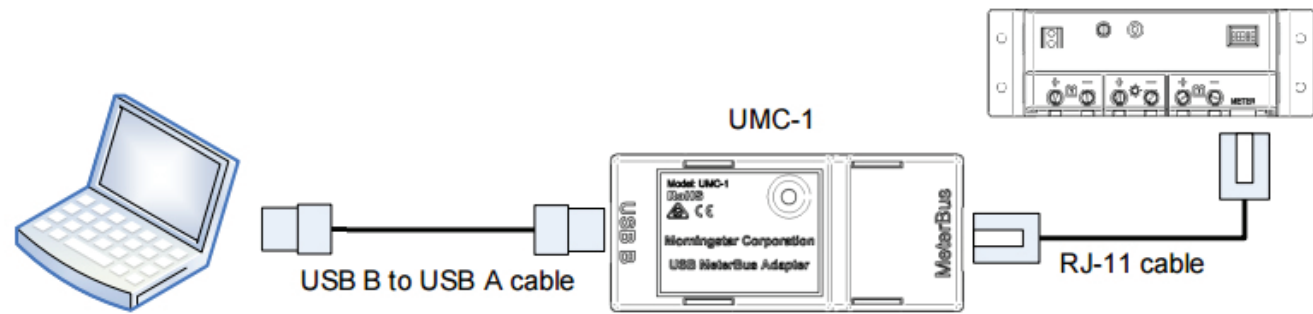

Figure 31. USB / RJ-11 Connection Diagram

Once connected, please refer to Section 5 on how to make Local Connections in MSView™.

4.2.5 USB / Serial (DB-9) / RJ-11

A less preferred method for connecting a computer that does not have a serial (DB-9) port with a Morningstar device that has only an RJ-11 port is to make two transitions from USB to serial (DB-9) and then from Serial (DB-9) to RJ-11. This requires a 3rd party USB to Serial (DB-9) with a Morningstar PC MeterBus™ Adapter (model: MSC). This was required before Morningstar introduced the UMC-1 adapter. Figure 32 below illustrates the proper connection.

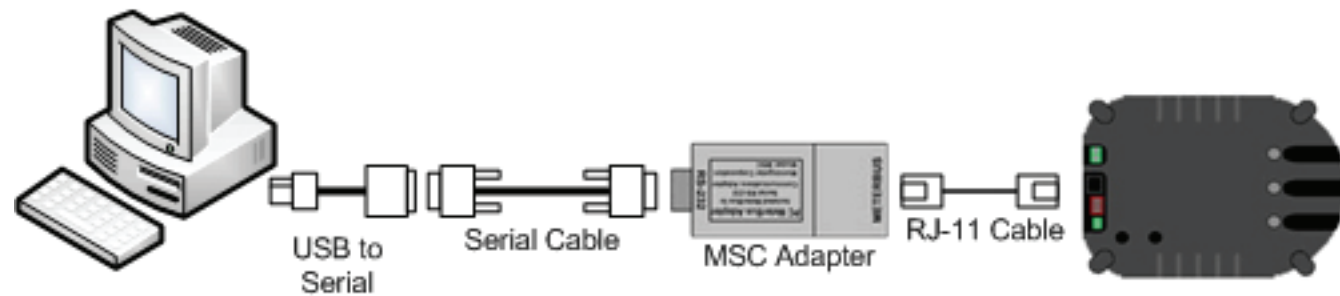

Figure 32. USB / RJ-11 Connection Diagram

Once connected, please refer to Section 5 on how to make Local Connections in MSView™.

4.2.6 Serial USB-A / USB-C

The GenStar MPPT controller has a USB-C port that can be used to make a USB connection to a PC or laptop USB. This can be used for MODBUS™ open protocol communications or for firmware updates (with MSLoad™ Software).

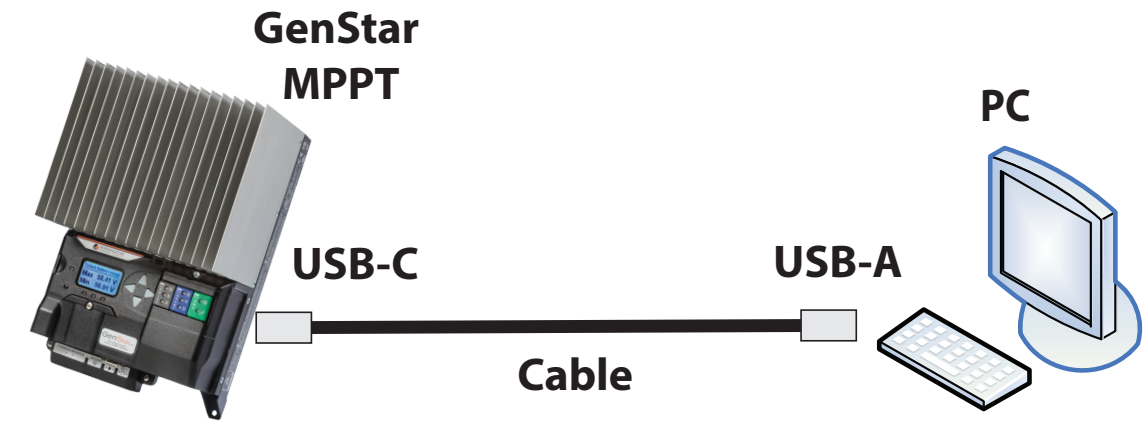

Figure 33. USB-A to USB-C Connection Diagram

4.2.7 Serial USB-A to USB-A

The SureSine inverter (700 W to 2,500 W Models) has a USB-A port that can be used to make a USB connection to a PC or laptop USB. This can be used for MODBUS™ open protocol communications.

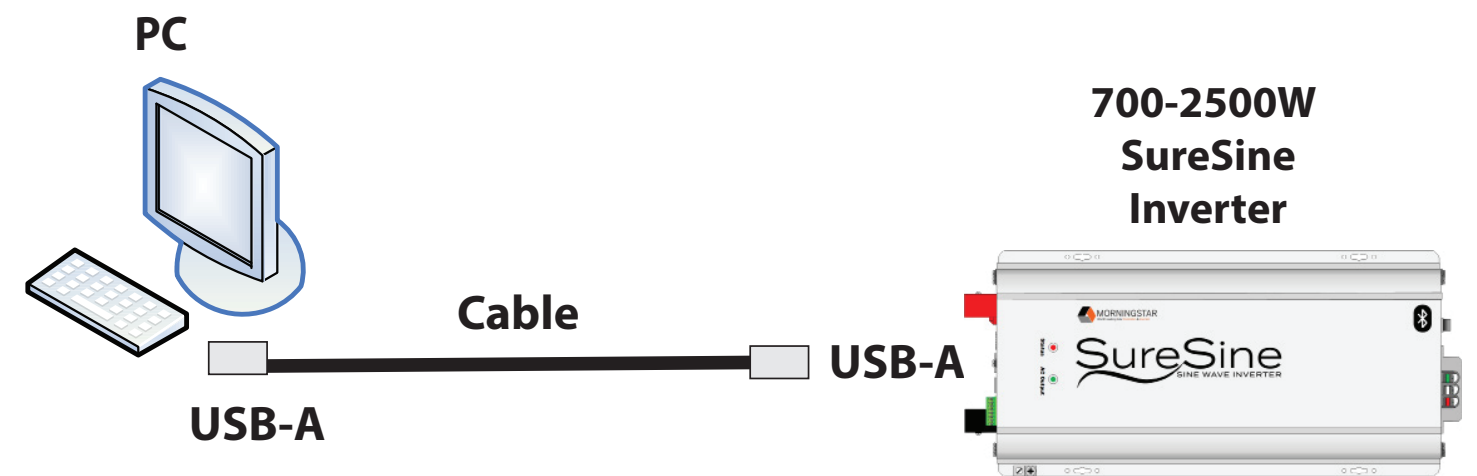

Figure 34. USB-A to USB-A Connection Diagram

4.2.8 Multiple Device Using EIA-485

In an EIA-485 network, each device connects via a serial EIA-485 bus network. The data connection A of all the devices are wired together, as are all the B data connections.

Morningstar's RS-232 / RS-485 Adapter (RSC-1) and TriStar MPPT controllers (60A models) require power from a 12VDC power source. Refer to Section 2.1.2 for more information on the RSC-1 adapter. Power -GND/ + is applied to the adapter as in Figure 35 below.

The MeterBus to EIA-485 Adapter (MRC-1) is capable of supplying isolated 12VDC power from the MeterBus to an EIA-485 network, eliminating the need for an external 12VDC bus power source in many cases. However, the power is limited. The MRC-1 power switch must be turned on in order to provide +12VDC power. When the MRC-1 power switch is off, it must be powered externally as with an RSC-1.

The GenStar MPPT supplies isolated power to the EIA-485 network, eliminating the need for an external bus power source in many cases. The GenStar MPPT EAI-485 includes a EIA-485 GND terminal that is wired to the Common GND(-) of the EIA-485 bus.

The new SureSine inverter includes isolated power to the EIA-485 network also and requires A and B data connections only. In addition, SureSine, 750-2500 Watt models, include an isolated 1 Watt, +12V auxiliary power that can be used to power the EIA-485 Bus.

Figure 35, below, illustrates how properly to connect equipment to the EIA-485 bus.

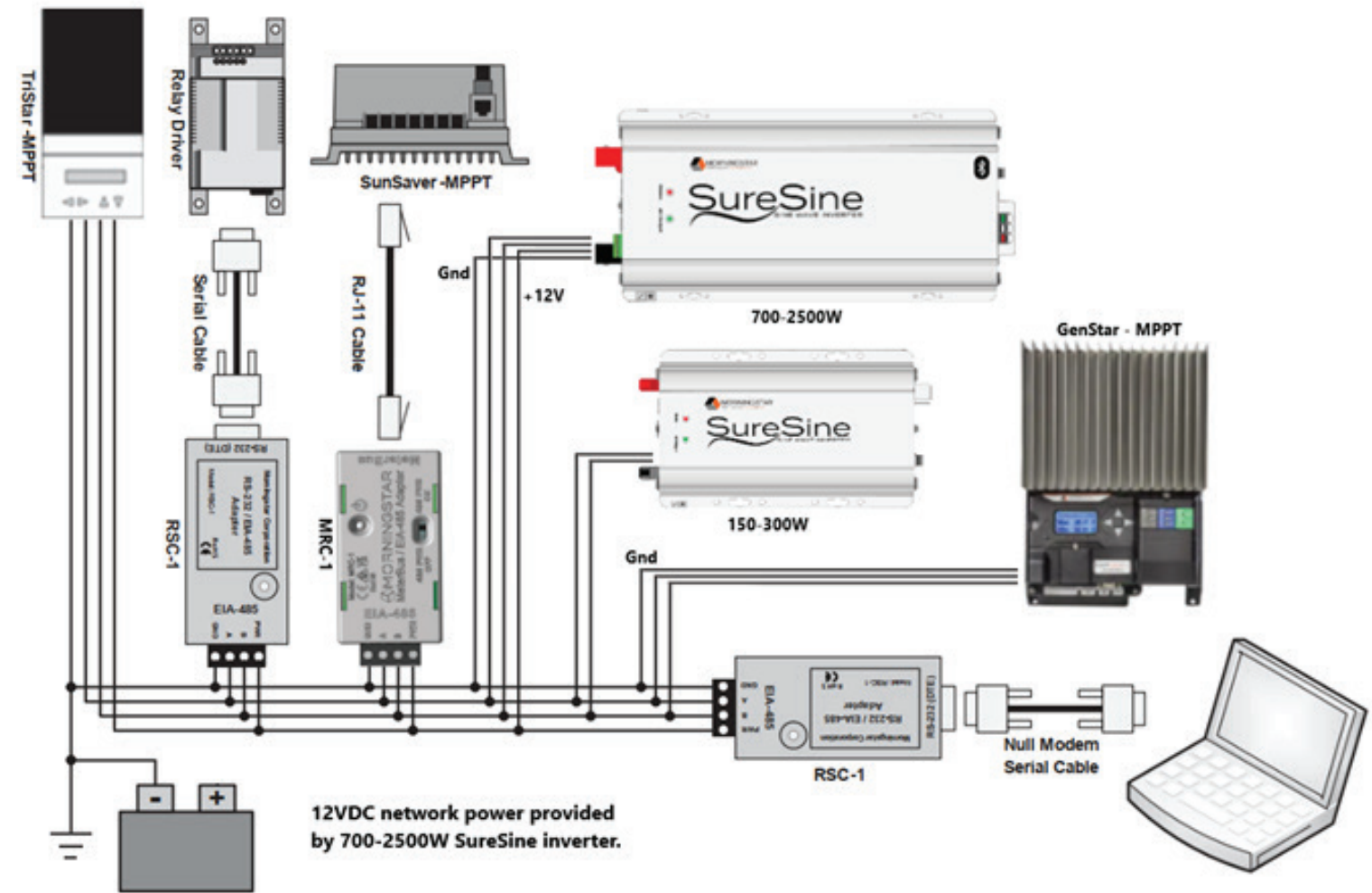

Figure 35. Multiple Device EIA-485 Bus Connection Diagram

NOTE: A NULL modem cable is used to connect the PC to the RSC-1 adapter.

Once connected, please refer to Section 5 on how to make Local Connections in MSView™.

4.2.9 Multiple Device Using USB Serial Hub

Multiple devices can be connected to a PC at the same time through the use of a USB Serial Hub. The USB hub expands the PC's number of USB ports, allowing for more Morningstar devices to be connected to the computer. As with a single USB Serial connection, an adapter cable may be required as needed for each device to be connected to the hub. Each USB / Serial cable is mapped to a different VCOM port. In this type of network, the PC communicates with one device at a time and the devices do not have the ability to communicate with each other. Figure 36 below illustrates the correct way to establish a multiple device connection via a USB hub.

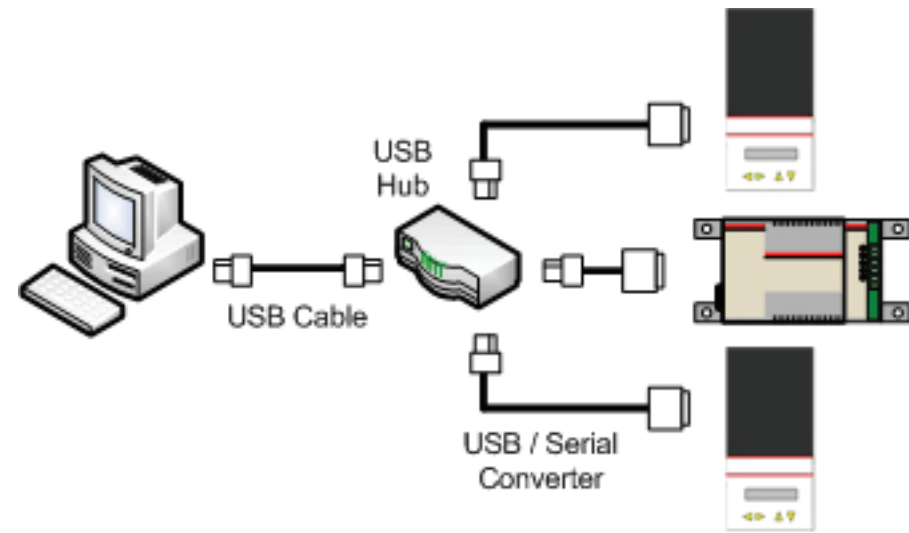

Figure 36. Multiple Device USB / RS-232 Connection Diagram

NOTE: USB cables longer than 5 meters risk signal loss.

To communicate properly, each controller must be assigned a unique Modbus™ ID address. Connect to each controller individually and use the appropriate MSView™ setup wizard to assign an address to each device. Modbus ID assignments can be made with the MSView™ setup wizard, local display settings for ProStar and ProStar MPPT controllers, or a MODBUS write command for new SureSine inverters.

Once a network is defined, refer to Section 5 on how to connect locally.

NOTE: USB Serial networks may also include devices connected to Morningstar's UMC-1 USB MeterBus™ Adapter.

4.3 Remote Connections

Remote connections are established between a PC and a device when IP addressing or cellular networks are used.

IMPORTANT: The connections described in this section often require extensive use of 3rd party hardware, as described in Section 2.2. When interfacing 3rd party hardware with Morningstar products using an RS-232 (serial) connection, it is essential that the proper voltage be applied to the Morningstar unit's DB-9 pins. Please refer to Section 11 Troubleshooting and Misc. (Serial Port Power with 3rd Party Devices) for detailed information.

4.3.1 Cellular Modem Network

Remote communication is capable over an existing cell network. Many cell service providers offer a modem versions of their cell phone hardware, allowing you to dial up to a remote site and transfer data wirelessly. This configuration is very similar to how a landline modem connection is used, however, wireless capability allows for connections to remote areas without landline access.

Using this type of connection requires a paid data plan subscription from your local cellular provider.

In areas where cell phone towers are not yet located or there is a poor signal, satellite modems can be used in a similar manner. Satellites in orbit relay the signal, instead of a land-based tower. Contact your cellular provider for information on plans, pricing, activation, and technical assistance.

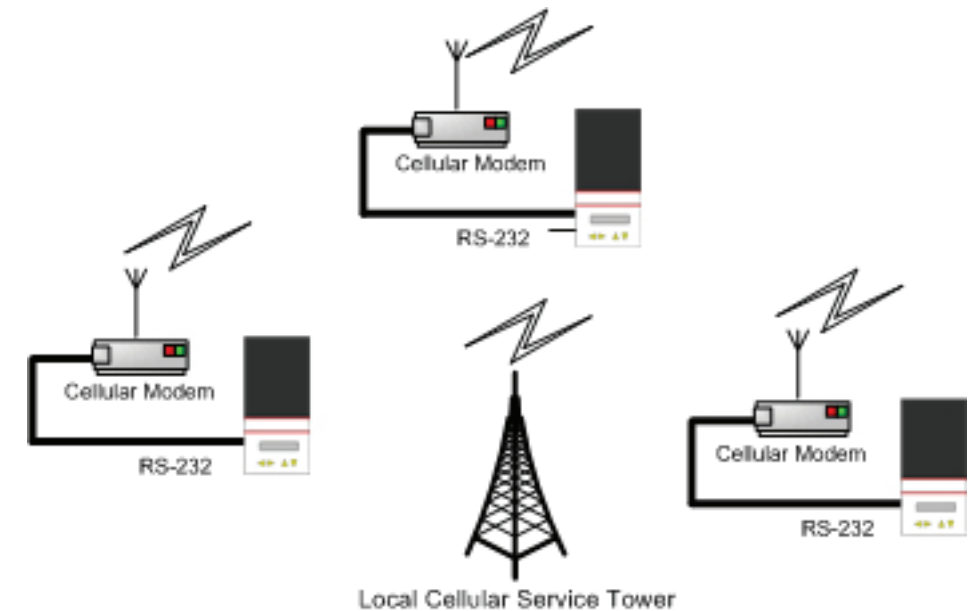

Figure 37. Cellular Network (paid service) Connection Diagram

Once connected, please refer to Section 5 for info on using MSView™. Cellular Modems are also available with RS-232 or EIA-485 serial port options.

4.3.2 Point-to-Point Wireless Transfer

When a hardwire connection is not feasible, but distances are shorter than would require a cellular connection, point-to-point wireless transfer using radio modems is recommended. Point-to-point wireless can usually cover a distance between 10 and 25 kilometers, however, range will vary depending on the model of radio modem and atmospheric/geographical conditions. One modem is connected to the PC, called the base radio, and the other is connected to the controller, called the field radio. There can be multiple field radios, but the base radio can only communicate with one at a time.

Signal encryption varies, yet it is recommended the most advanced encryption available is used. Data transmitted over the airwaves is much easier to intercept than data over a wired connection. Proper encryption will ensure your data is protected.

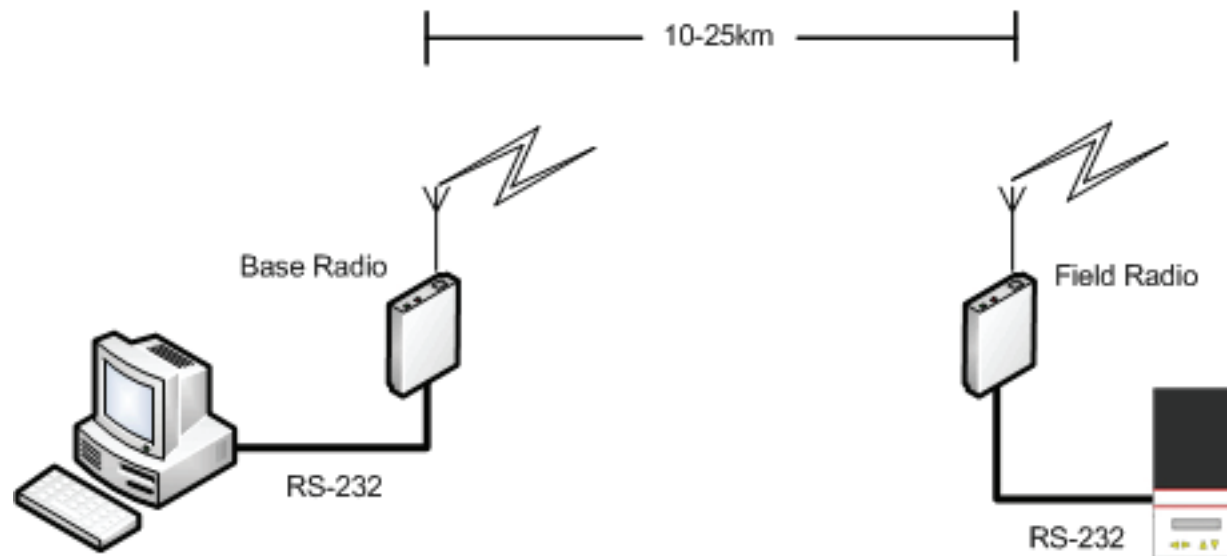

Figure 38. Point-to-Point Wireless Connection Diagram

Once connected, please refer to Section 5 on how to make Local/Remote Connections in MS-View™.

4.3.3 Internet (Ethernet/RJ-45)

4.3.3.1 Ethernet / Ethernet

Ethernet crossover cables may be required to connect a PC's Ethernet port directly to a controller or with the EMC-1. Although this type of connection is considered 'local' in the physical realm, its use of IP addressing makes it a remote connection as far as software communications are concerned. Morningstar's MSView™ software has the option to use Remote (TCP) Settings. The LiveView HTML web page can also be accessed with this type of connection. The GenStar MPPT controller TCP settings can be set up in LiveView or with the local meter display. Changing the IP Address of the PC will typically be required for a direct connection to the controller. Detailed information concerning remote communication settings can be found in Section 5.3.

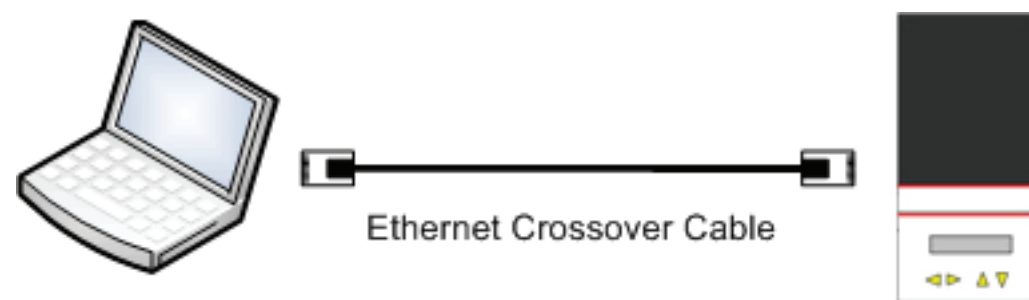

Figure 39. Ethernet Crossover Connection Diagram

Once connected, refer to Section 5 for making Remote Connections in MSView™.

4.3.3.2 Ethernet to RJ-11 or Ethernet to RS-232 with EMC-1

If your Morningstar device does not include an Ethernet port the simplest solution is to use the EMC-1 Ethernet Converter. For Morningstar controllers and inverters which only have an RJ-11 port the EMC-1 converts directly from Ethernet to the RJ-11. For Morningstar devices which includes an RS-232 port the EMC-1 will convert from Ethernet to RS-232. Figure 40, below, illustrates the proper connection with Ethernet to RJ-11.

Setup is similar to Ethernet to Ethernet described in subsection 4.3.3.1 and may require an Ethernet Crossover cable. The EMC-1 also provides an LiveView HTML web page for the connected product which can be accessed with this type of connection.

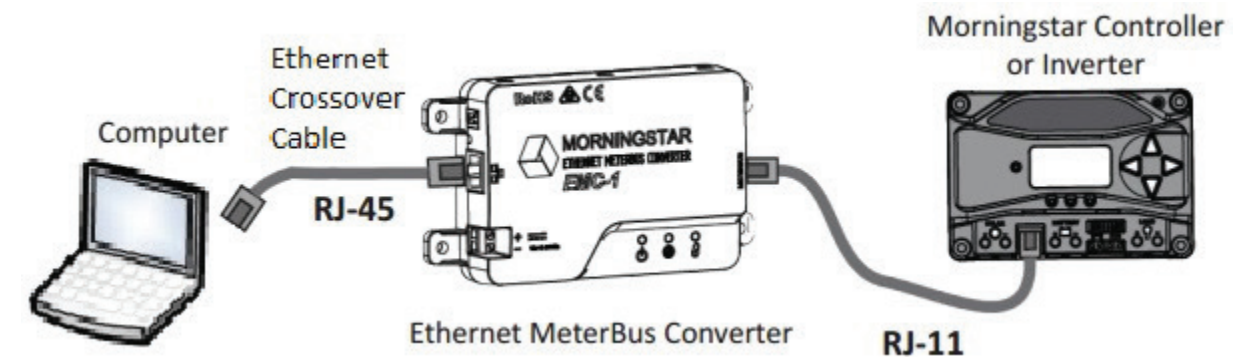

Figure 40. Ethernet Crossover Connection Diagram with EMC-1

Once connected, please refer to Section 5 on how to make Remote Connections in MSView™.

4.3.3.3 Ethernet to Serial

The EMC-1 is recommended. However, it is possible to connect serially to your controller/inverter using your PC's Ethernet connection and an Ethernet to serial converter. Although this may appear to be a local connection, it is in fact a remote connection because the Ethernet to serial converter will be assigned an IP address.

The converter should come with software making it easy to discover or assign its IP address. The MSView™ software needs to know the converter's IP address in order to make a connection. Figure 41, below, illustrates the proper physical connections.

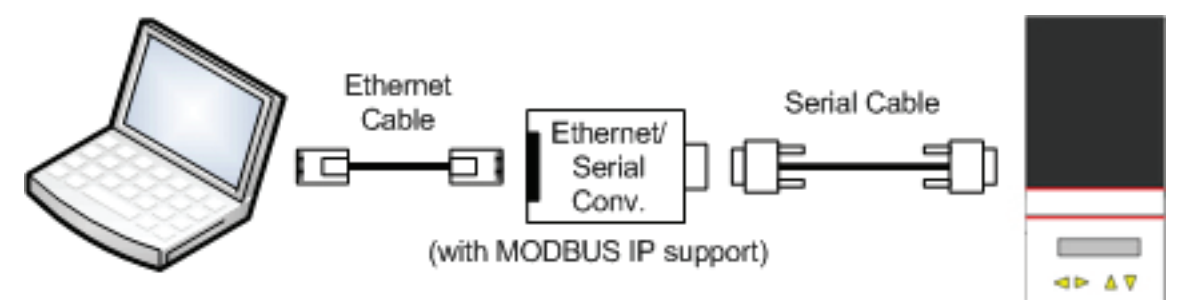

Figure 41. Ethernet to Serial Connection Diagram

NOTE: An MSC adapter may be used to connect to a device with only an RJ-11 MeterBus™ port.

Once connected, refer to Section 5 for making Remote Connections in MSView™.

4.3.3.4 LAN/WAN/Internet

IP addressing allows you to connect to a device over a Local Area Network (LAN), Wide Area Network (WAN) or from across the globe using the Internet. There are many different physical configurations allowing for such connections, however, their unifying attribute is the use of IP addressing.

In Figure 42, below, both the PC and the controller have a unique network IP address. The PC can use the controller's IP address to poll it for data. Although they are on the same local network, the connection process is very similar to Figure 43 where the PC and controller are connected through the Internet.

Controllers that do not have an Ethernet interface can still be connected in this way through the use of the EMC-1 Ethernet to MeterBus™ Converter or an Ethernet to serial converter and (if necessary) a MeterBus™ Adapter (MSC).

MSView™ can be used with these types of connections. LiveView is also available with both LAN and Internet connections for controllers and inverters which have an Ethernet port or when using the EMC-1 Converter.

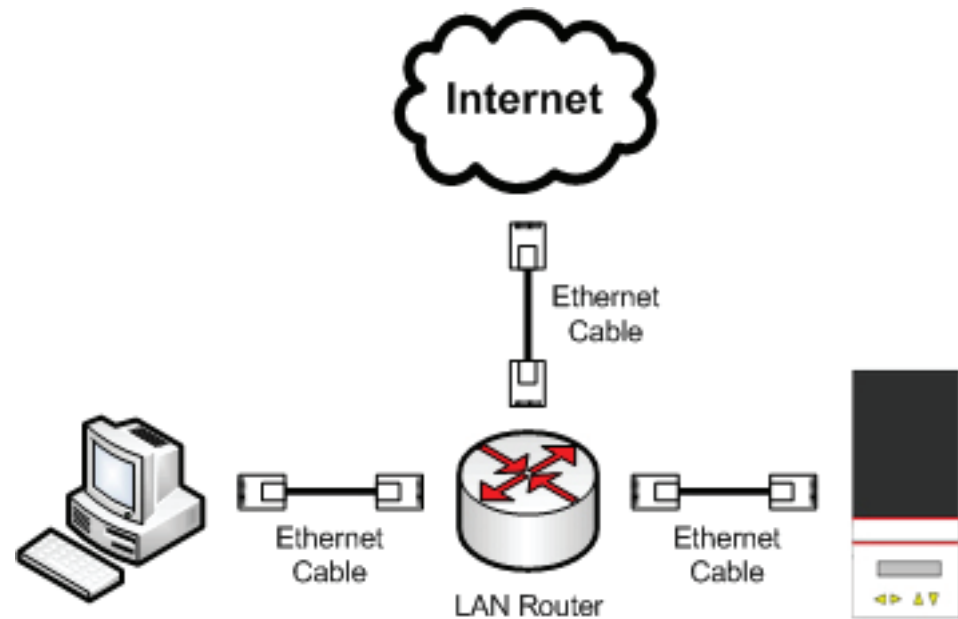

Figure 42. LAN Connection Diagram

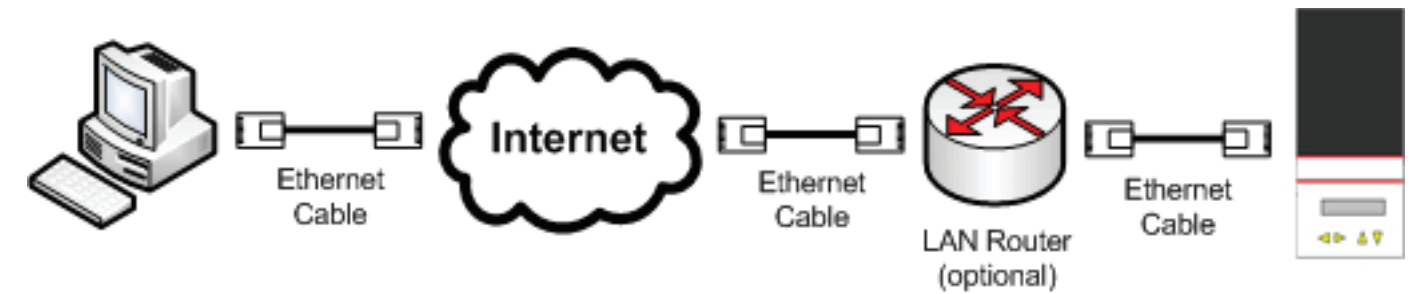

Figure 43. Internet Connection Diagram

Once connected, please refer to Section 5 on how to make Remote Connections in MSView™.

4.3.3.5 Cellular Router Internet

Cellular Routers are available that can provide TCP/IP access to MODBUS™ Ethernet and/or RS-232/EIA-485 Serial Devices.

In areas where cell phone towers are not located, satellite routers can be used in a similar manner. Satellites in orbit relay the signal, instead of a land-based tower. Contact your cellular provider for information on plans, pricing, activation, and technical assistance.

4.3.4 Multiple Device Data Network (EIA-485)

An EIA-485 network can be established remotely as well as locally (Subsection 4.2.8). The GenStar MPPT and 60A TriStar MPPT controllers can act as can act as a MODBUS™ RTU leaders and will - if selected - bridge MODBUS™ requests to the EIA-485 network, allowing remote access to any device on the EIA-485 network. Most Ethernet to Serial converters, discussed in Subsection 2.2.14, will provide the same bridging capability. Cellular Routers are also available with Serial connections. Such a configuration allows for data logging, programming of custom settings, and management of all controllers on the MODBUS™ 485 network. Figure 44, below, shows a diagram of the proper connections for a remote EIA-485 network when using a 60A TriStar MPPT controller.

The Ethernet label indicates that any Ethernet communication configuration discussed in this manual is suitable for use with the EIA-485 network.

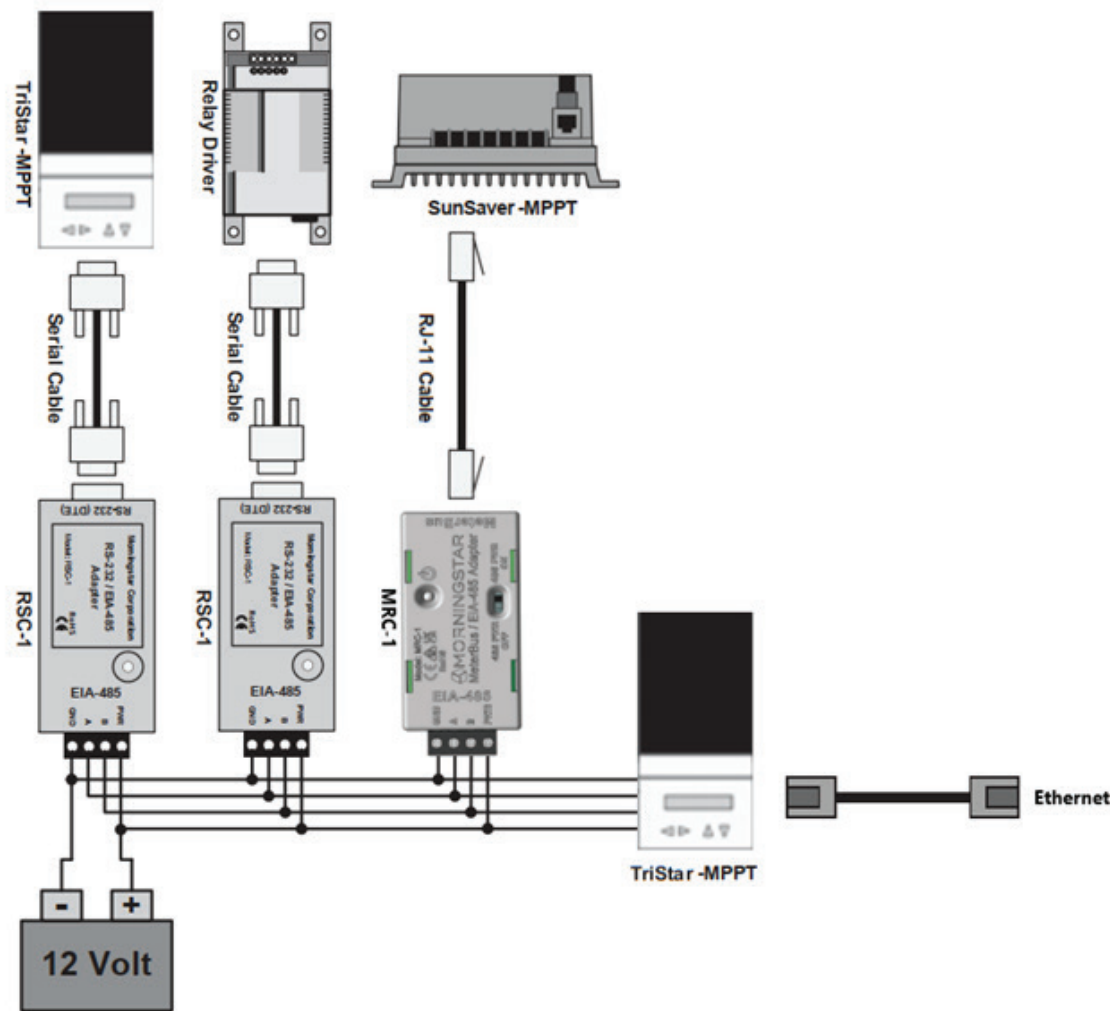

Figure 44. Remote EIA-485 (w/ TSMPPT Bridge) Connection Diagram

4.3.5 Multiple Devices via LAN/WAN/Internet

Multiple devices can communicate via Ethernet connections in the same way a single device communicates with a PC. Several devices can be connected to a single LAN router or directly to the Internet. Each device (or Ethernet to serial converter) will have its own IP address, enabling communication with your Internet-connected system. Figure 45, below, illustrates multiple device Ethernet connections. Both a single serial port converter and a multiple port converter are illustrated. (Some models of Ethernet to Serial converters have multiple serial ports.)

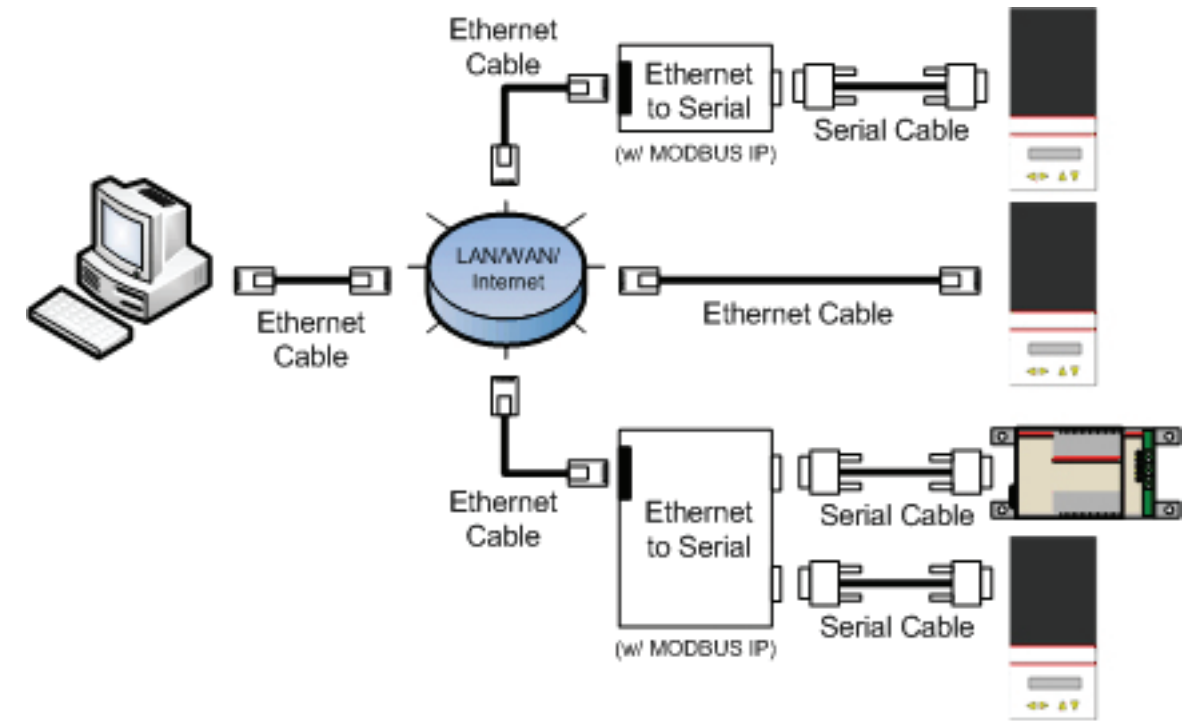

Figure 45. Multiple Device Ethernet LAN/WAN/Internet Connection Diagram

4.3.6 Multiple Devices via MODBUS™/MeterHub Network

Instead of using the MeterHub to create a MeterBus™ network, a MeterHub can also be used to create a MODBUS™ Network. With this type of network, the PC communicates with one device at a time, and the devices aren't able to communicate with each other.

In a MODBUS™/MeterHub Network, multiple Morningstar devices can be connected using a single RJ-11 MeterBus adapter (MSC, UMC-1, or EMC-1). In such a system, the ProStar MPPT, ProStar Gen 3, SunSaver Duo, SunSaver MPPT, and Suresine Classic, which do not have a standard RS-232 connection, can be used with a MeterHub.

Figure 46 below illustrates how to establish a multiple device connection over RS-232 via a Morningstar MSC PC MeterBus™ Adapter with a MeterHub.

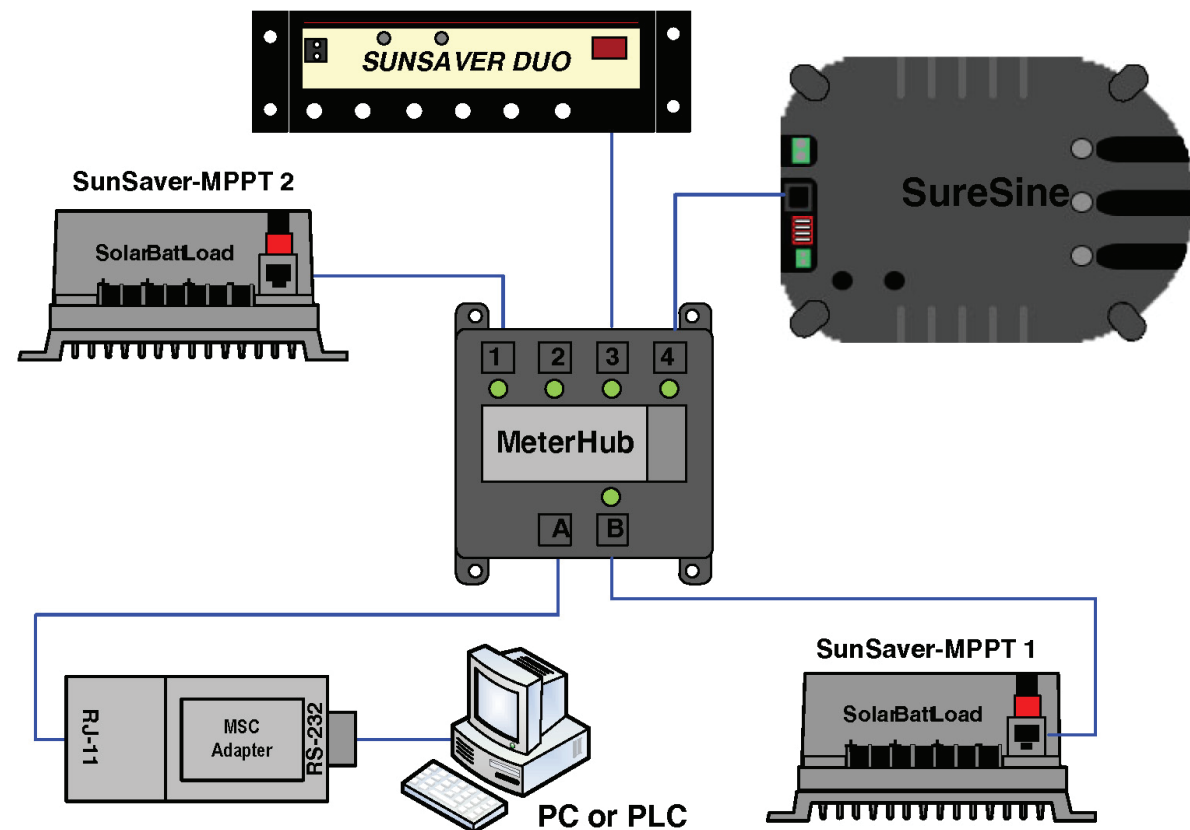

Figure 46. Multiple Device MODBUS™/MeterHub Network.

To communicate properly with each controller, a unique MODBUS™ ID must be assigned to each unit. To do this, connection must be made to each controller individually, and the appropriate MSView™ setup wizard used to assign an ID. MeterBus™ Adapters require power from the MeterBus™, so they must be connected to Port A of the MeterHub as indicated in Section 3.2.2 - Table 2. **NOTE:** If the device requires a DIP Switch change to enable MODBUS communication, the switch must be in the appropriate position, and the device must be reset (power-cycled) to enable proper network communication.

Once connected, please refer to Section 5 on how to make Local Connections in MSView™.

The MeterHub can also provide multi-device MODBUS™ connections for Morningstar's UMC-1 MeterBus™ Adapter and EMC-1 Ethernet Converter.

The EMC-1 will provide a LiveView web page for only one Morningstar device in the MODBUS™/MeterHub network. However, the EMC-1 will provide access to all connected devices through MSView or 3rd party MODBUS software. Using the EMC-1, SNMP can be used with one compatible Morningstar device at a time - see list in Section 8.1.

NOTE: With each additional device added to a MODBUS™/MeterHub Network, communications can become slower, and therefore less reliable.

5.0 MSView™

5.1 Overview

The MSView™ software package is used by your PC to change custom settings, view real-time controller data, download internally logged data, log data in real time and view historic data graphically. Configuration wizards make it easy to customize the features of the device, while an intuitive directory tree organization of variables puts real-time data at your fingertips.

MSView™ uses the open-source MODBUS™ protocol described in Subsection 1.1.2. This means any MODBUS™ capable software is able to access data stored in the controller, however, the use of MSView™ for this purpose is highly recommended.

MSView™ is free and can be downloaded from the Morningstar web site (found in the Software Library on the Tech Support page). MSView™ supports the following Morningstar products: TriStar MPPT, TriStar PWM, ProStar MPPT, ProStar PWM, SunSaver MPPT, SunSaver Duo, SureSine Classic and Relay Driver. The GenStar MPPT controller and new SureSine inverters are not supported by MSView™.

NOTE: MSView™ is a Windows-based application but there are various ways to run Windows programs on Apple Mac and Linux operating systems. A web search for "how to run windows programs on mac" will provide many options. Note that some of these options will be compatible with TCP/IP Ethernet connections but may not support USB or other Serial connections.

System Requirements

- Intel® 486 or Pentium® processor (or equivalent)
- Microsoft® Windows 95, 98, 2000, Windows XP Professional or Home Edition, Vista, Windows 7, Windows 8.1, Windows 10
- 32MB of RAM (64MB Recommended)
- CD-ROM drive (If installing by CD)
- Up to 1.5MB of available hard-disk space
- Internet connection and service (If downloading from web)
- Web browser (If downloading from web)



NOTE: In order to customize settings through MSView™, certain DIP switches must be set on the controller. Refer to Table 3, at the end of this Section, for proper settings.

5.2 Installation

On the Morningstar web site (www.morningstarcorp.com), download the MSView™ file and save it to your PC. The file should be in .zip format, meaning the contents will have to be extracted before installation can proceed. Windows ME, XP and later have local unzip capabilities. If you are not running one of these later versions of Windows, you must download a zip/unzip utility. We recommend WinZip™, a trial version of which can be downloaded at www.winzip.com. Please refer to the WinZip™ web site for instructions on how to unzip the MSView™ file. Newer versions of MSView™ do not require installation. After unzipping the download folder, double-click on the MSView™ icon to run the program.

5.3 Establishing a Connection

Specific steps for making device connections are not outlined in this document. Refer to the MSView™ *Help Topics* in the program for all the information needed to make device connections.

5.3.1 Local (Serial) Settings

If using one of the following:

- Serial to serial connection
- USB to serial connection (USB to serial Adapter)
- Serial to RJ-11 (MeterBus) connection (PC MeterBus™ Adapter)
- USB to RJ-11 (MeterBus) connection (UMC-1 USB MeterBus™ Adapter)
- USB to RJ-11 (MeterBus) connection (USB to serial Adapter to PC MeterBus™ Adapter)

you are attempting to establish a local connection.

3rd party USB Adapters

Connecting via USB with 3rd party adapters requires additional driver software provided by the manufacturer with a CD and/or on their web site. You will need to install the driver needed to create a Virtual COM Port.

Once you have the Virtual COM Port Driver installed, you *MAY* need to determine which port number the driver has allocated for USB use. Go into **My Computer** and click *View System Information* on the left hand side of the window. View the *Hardware* tab and click on *Device Manager*. You should see a tree structure used to view the hardware connected to your PC. The COM port number allocated by the newly-installed driver can be found by expanding the *Ports* branch. Usually, the name of the driver you just installed will be visible with the COM port designation next to it in parentheses. **Note:** If the COM port number is greater than 30, plug into a different USB port and check the number again.

5.3.2 Remote (TCP) Settings

If using one of the following:

- Ethernet (via direct/LAN/WAN/Internet)
- Ethernet to RJ-11/RS-232 with EMC-1 (via direct/LAN/WAN/Internet)
- Ethernet to serial (via direct/LAN/WAN/Internet)
- Cellular modem with MODBUS IP capability
- you are attempting to establish a remote connection.

5.3.3 Connect

If the connection attempt was successful, there should be a green device icon in the Edgebar of the MSView™ workspace. The label will display the connected device's name and serial number.

5.4 Creating A New Display

The MSView™ software is frequently updated. Therefore, specific steps for making creating and populating a new display in the workspace are not outlined in this document. Please refer to the *Help File* in the MSView™ program for all the information needed to create and populate data displays.

5.5 Setup Wizards

MSView™ provides several Setup Wizards designed to make configuring and customizing your Morningstar product quick and simple. Currently six (6) wizards are available: Relay Driver, Sun-Saver Duo Setup, SunSaver MPPT Setup, TriStar DIP Switch, TriStar Setup, and TriStar MPPT Setup. These are accessible through the **Tools** menu.

5.5.1 Relay Driver Wizard

Each of the four channels on the Relay Driver is assigned a function which will switch the channels on/off depending upon specified criteria. This wizard will assist you in defining these functions and customizing the RD to your needs.

The following functions are available:

- Disabled - disables the channel and allows for input voltages/signals to be read on that channel.
- Threshold - switches a channel on/off according to a low threshold and a high threshold defined by the user.
- Alarm/Fault - monitors faults and alarms from a Morningstar Device over the MeterBus™ connection and activates the channel when specified alarm(s) or fault(s) occur. (Each channel can only monitor alarms/faults from one device.)

- GenStart - configure up to three (3) channels to control a generator. Refer to the generator manual for required signals, timing, and other specifications.
- MeterBus™ Follower - allows a Morningstar device to control a Relay Driver channel directly.
- MODBUS™ Follower - allows direct control over a channel via serial connection with a PC or other MODBUS™ compatible device.

For more information on the step by step use of this wizard, please refer to the **Help Topics** in MSView™.

5.5.2 SunSaver Duo Setup Wizard

Custom settings can be programmed to the SunSaver Duo via MSView™. This wizard allows for step by step specification of these settings. After selecting the SSD Setup Wizard, please read the warning and select OK if you accept the terms.

 **NOTE: DIP switch 4 must be ON to use custom setpoints. Disconnect power from the controller before changing any DIP switches; failure to do so will cause a fault.**

A custom setpoints table is displayed along with several buttons allowing to read/write the setpoints to a file, read setpoints from the SSD, program to the SSD, edit displayed setpoints, or create a new setpoint profile. The next screen prompts the user for two sets of custom setpoints for Battery 1. DIP switch 1 will select between these two sets. Click Next when finished to customize settings for Battery 2. DIP switch 2 will select between Battery 2's setpoint profiles.

Common setpoints are shared between all sets of custom setpoints and will specify charging priority, temperature compensation, load, lighting and MeterBus™/MODBUS™ ID address. DIP switch 3 toggles between sets of charging priority setpoints.

For more information on specific custom setpoints and their effects, please refer to the **Help Topics** in MSView™.

5.5.3 SunSaver MPPT Setup Wizard

Custom settings can be programmed to the SunSaver MPPT via MSView™. This wizard allows for step by step specification of these settings. After selecting the SSMPPT Setup Wizard, please read the warning and select OK if you accept the terms.

 **NOTE: DIP switch 1 must be ON to use custom charge settings. Disconnect power from the controller before changing any DIP switches; failure to do so will cause a fault.**

 **NOTE: DIP switch 4 must be ON to for MSView™ to communicate successfully using MODBUS™.**

As you progress through the wizard, you will be able to specify two sets of charge settings: Setting 1 active when the Battery Select Jumper is Inserted and Setting 2 active when it is

removed. Shared charge settings are also defined, along with Load settings. Finally, MeterBus™/Modbus™ ID address and LED transition threshold voltages can be set.

For an in-depth description of charge settings, load settings, and transition voltages, please refer to the **Help Topics** in MSView™.

5.5.4 ProStar (Gen 3) & ProStar MPPT Setup Wizards

Custom setpoints are programmed into the ProStar and ProStar MPPT via MSView™. This wizard allows for step by step specification of these settings. After selecting ProStar Setup Wizard, please read the warning and select OK if you accept the terms.

Progressing through the wizard, the user specifies absorption, float and equalize charging setpoints, along with appropriate temperature compensation. The ProStar has load settings which includes low voltage disconnect/reconnect, load current compensation and high voltage disconnect/reconnect as well as lighting settings and finally communication settings to define MeterBus™/Modbus™ ID address.

For an in-depth description of charge settings, load settings, and transition voltages, please refer to the **Help Topics** in MSView™.

5.5.5 TriStar DIP Switch Wizard

The TriStar has eight DIP switch settings which need to be properly configured for correct operation of the controller. The TriStar DIP Switch Wizard provides step by step instructions for determining appropriate DIP switch positions. The wizard will prompt the user for the desired operational parameters and provide a graphical representation of the appropriate DIP switch configuration. The wizard cannot change the switch settings for the user; the user must physically position the switches according to the wizard's recommendations.

 **NOTE: Disconnect power from the controller before changing any DIP switches; failure to do so will cause a fault.**

Please refer to the **Help Topics** in MSView™ for more information.

5.5.6 TriStar Setup Wizard

Custom settings can be programmed to the TriStar via MSView™. This wizard allows for step by step specification of these settings. After selecting the TriStar Setup Wizard, please read the warning and select OK if you accept the terms.

 **NOTE: Use the TriStar DIP Switch Wizard to correctly set the system voltage. Disconnect power from the controller before changing any DIP switches; failure to do so will cause a fault.**

Depending in which mode the TriStar will be used, the wizard will allow the user to set appropriate settings for that mode. Each mode (Charge, Load, Lighting, Diversion) are

programmed into the controller separately. Solar Charging Control will permit PWM, temperature compensation, HVD (high voltage disconnect), equalization, LED transition, and address settings to be modified. Load Control allows LVD (low voltage disconnect), HVD, and LED transition settings to be specified. Diversion Control enables PWM, HVD, Float, Equalize, LED transition and addressing modification. Finally, Lighting Control permits load timing, dusk/dawn detection, LVD/HVD, and LED transition adjustments.



NOTE: All setpoints must be specified for a nominal 12V system. When DIP switches 2 & 3 are used to specify system voltage, setpoints are multiplied accordingly.

More information on individual controller settings are found in the **Help Topics** of the MSView™ software.

5.5.7 TriStar MPPT (150V & 600V) Setup Wizards

Custom setpoints are programmed into the TriStar MPPT via MSView™. This wizard allows for step by step specification of these settings. After selecting TriStar MPPT Setup Wizard, please read the warning and select OK if you accept the terms.

Progressing through the wizard, the user specifies absorption, float and equalize charging setpoints, along with appropriate temperature compensation. The TriStar MPPT has an internal logging feature which is configured next. The user may choose which system variables are to be logged internally to the MPPT unit. Communication settings are then defined for both basic RS-232 serial use and for Ethernet connectivity. Finally, the wizard allows you to configure the unit's four available notifications (see Section 8).

More information on individual controller settings are found in the **Help Topics** of the MSView™ software.

DIP Switch Positions to Enable Custom Settings, MODBUS™ with a MeterBus™ port and Ethernet Write Commands

Device	Enable Custom	Enable MODBUS	Enable Ethernet Write
SunSaver Duo	4 ON (up)	N/A	N/A
SunSaver MPPT	1 ON (up)	4 ON (up)	N/A
ProStar (Gen 3)	4, 5 & 6 ON (up)	N/A	N/A
ProStar MPPT	4, 5 & 6 ON (up)	8 ON (up)	N/A
TriStar*	4, 5 & 6 ON (up)	N/A	N/A
TriStar MPPT*	4, 5 & 6 ON (up)	N/A	8 ON (up) for TS-MPPT-60
Suresine Classic	N/A	4 ON (up)	N/A
EMC-1	N/A	N/A	1 ON (up)

Table 3. Morningstar Device Custom Settings DIP Switch Positions

*MeterBus™ and Modbus™ ID address will ALWAYS be updated, regardless of DIP switch settings. (i.e. if custom settings are specified in MSView™ and are uploaded to the controller without switches 4,5,6 ON, only the MeterBus™ and Modbus™ ID address will be updated and *not* custom charge settings)

6.0 Firmware Updates

6.1 Overview

Periodically, Morningstar will release product firmware updates. These updates will fix minor operational bugs, adjust operating parameters for better battery charging, or add additional features. Firmware updates are free and posted, as they become available, on the Morningstar web site at www.morningstarcorp.com.

For the majority of Morningstar products, MSLoad™ is the software program that is used to upload new firmware. For newer Morningstar products, other options may be available for uploading firmware including LiveView with an Ethernet connection or using a Mobile App with a Bluetooth connection.

6.2 Uploading Firmware with MSLoad™

The MSLoad™ program must be downloaded from the Morningstar web site, along with the firmware update file for your specific product. Once you have downloaded these two items, save them to your desktop.



NOTE: Firmware updates may overwrite custom setpoints and configurations. Be sure to save programmed settings before performing a firmware update.

Remove power from the device and perform the following:

- Extract the MSLoad™ .zip file and run the program.
- Browse for the firmware file you saved on your desktop.
- Specify the communications port to which the controller is connected. If using a USB to serial adapter, refer to the *USB* portion of Section 5.3.



NOTE: MSLoad™ firmware updates can only be done through a serial connection. An Ethernet connection cannot be used. Disconnect or power off all other devices in the EIA-485 network when uploading firmware using an EIA-485 connection.

- Apply power to the device when prompted by the program.
- Allow approx. 1-5 minutes for completion of the firmware update.
- Cycle power to the controller (remove power, then re-apply power) for the firmware update to take effect



IMPORTANT: Some controllers (like the TSMPPT) contain two microprocessors. These units will need a firmware update for each processor. Such update files will be designated 'A' and 'B'.

TriStar Meters (models TS-M-2, TS-RM-2 and TS-M-2-600V) have an RJ-11 port but cannot be firmware updated directly. An example is the TriStar Meter 2 (TS-M-2). Updates to TriStar meters are done through use of a TriStar or TriStar MPPT.

The RS-232 port used to update TS or TSMPPT firmware is the same as is used to update the TriStar meter firmware. The Meter is connected to the TS/TSMPPT via an RJ-11 MeterBus™ cable and the TS unit is used as a bridge to upload the new software to the Meter accessory.

For both situations, the firmware upgrade procedure is the same as outlined above.

Please refer to the Tech Support page on the Morningstar web site if you have difficulty upgrading controller firmware.

6.3 Uploading Firmware with LiveView

GenStar MPPT firmware can be installed using LiveView 2.0, the local meter display or MS Load. The EMC-1 firmware can only be installed with LiveView.

In order to update the firmware with the meter display, the firmware must first be saved to an SD card from a PC and then inserted into the SD card slot on the GenStar. In LiveView 2.0, with the GenStar MPPT controller and future products, select the UPDATE tab on the right side of the screen to open the Update view. Follow the directions on the screen to upload the firmware file from the SD card, and perform the firmware update.

The EMC-1 firmware can be updated through the LiveView Web page for the device that is connected to the EMC-1. Select the System tab on the right side of the LiveView page to open the System view. Follow the directions on the screen to upload the firmware file from the PC, and perform the firmware update for the EMC-1. Note that the connected device firmware cannot be updated through the System Web Page.

6.4 Uploading Firmware with Local Meter Display

The GenStar MPPT is the only Morningstar product that allows you to upload the firmware using the local meter display. This feature may also be available with future products.

In order to update the firmware with the meter display, the firmware must first be saved to an SD card from a PC and then inserted into the SD card slot on the GenStar. Navigate to the setup screen on the display meter and enable Installer setup. Then select Firmware and Load Firmware from the Installer Setup menu on the display and select the file from the SD card to upload the new firmware. See the GenStar MPPT Operation Manual and Meter Map for more details.

6.5 Uploading Firmware with BlueTooth Mobile Utility App

GenStar MPPT controller firmware can also be updated using the Morningstar Mobile App. Currently, the only way to update the firmware for new SureSine inverters is with the SureSine Mobile App. After connecting to the app, navigate to the Update Screen on the lower right and follow directions to upload the new firmware version. Once started, the app must maintain the BlueTooth connection until the update is completed

7.0 Web site Hosting via HTTP

7.1 Overview

Morningstar controllers with local Ethernet or EMC-1 Ethernet/MeterBus™ Converters used with Morningstar controllers or inverters will serve a collection of web pages enabling the following:

- view real-time system data
- view internally logged historical data
- modify controller network settings
- firmware updates (for the EMC-1 only)

The GenStar MPPT controller features the new LiveView 2.0 with the following additional features.

- send control commands
- view settings
- modify all settings with setup menus
- firmware updates
- Integrates with ReadyBlock/ReadyRail products

Access to the served LiveView web pages from a computer on a network can be achieved via two methods using an Internet browser (such as Internet Explorer, Google Chrome or Firefox):

- 1) Enter the Morningstar Device's IP address into the Address bar e.g. <http://192.168.1.186>.
- 2) Enter a Morningstar Device's NetBIOS name [product abbreviation + 8-digit serial no.] into the Address bar e.g. <http://ssmppt15320850>

Device	Product Abbreviation
SunSaver Duo	ssduo
SunSaver MPPT	ssmppt
ProStar (Gen 3)	pspwm
ProStar MPPT	psmppt
TriStar*	ts
TriStar MPPT*	tsmppt
Suresine Classic	suresine
GenStar MPPT	gsmppt

Table 4. Product NetBIOS Abbreviations

NOTE: Many networks are DHCP-enabled, and the IP address assignment will change after some period of time. The NetBIOS address is a static Morningstar Device identifier, and will always point to the Morningstar Device. These served web pages cannot be customized in layout or data displayed and only one controller's data can be viewed per page.

7.2 Port Information

Controllers with web serving capability use the standard HTTP Port 80 for communications. In addition, Port 502 is used for MODBUS TCP™ communication. To access the controller remotely, the router to which the unit is connected must be configured for port forwarding. Port forwarding commands the router to direct all incoming Internet traffic on a certain port to a computer or other device on your private network. In this case, we want to direct all incoming requests on port 502 to the Morningstar controller.

Optionally, you can also forward port 80 to the controller. By doing so, you will be able to remotely access (from outside your network) web pages served by the unit.

There are many different router models, so we cannot provide specific direction in this document for configuring port forwarding. However, the web site:

<http://www.portforward.com>

provides a comprehensive list of routers and instructions for port forwarding.

8.0 SNMP

8.1 Overview

Morningstar's TriStar MPPT controllers (60A, 150V and 600V versions) provide alerts via E-mail, SMS (text message), or SNMP trap. Notifications can be enabled for the following conditions:

- Self diagnostics fault condition (i.e. battery voltage sense failure)
- Self diagnostics alarm condition (i.e. high-temp current limit)
- User-defined event (i.e. battery voltage < threshold, load current > threshold)

Such alerts can be configured via the controller's network settings web page or in the MSView™ software. A maximum of four separate e-mail/SMS/SNMP alerts can be configured per device.

In addition to the custom alerts and trap notification settings - only available with 60A TriStar MPPT models - in MSView, many Morningstar products can be equipped with real-time SNMP data monitoring through the use of the available Ethernet MeterBus Converter (EMC-1) accessory device. The following Morningstar products are supported:

- MPPT controllers: TriStar MPPT, ProStar MPPT, and SunSaver MPPT
- PWM controllers: TriStar, ProStar (Gen3)
- Inverters: Suresine Classic

Morningstar's GenStar MPPT controllers also include real-time SNMP data monitoring.

8.2 SNMP Polling (EMC-1 and GenStar MPPT)



NOTE: The default IP port assignment for the SNMP Agent Receiver is 161

Several Morningstar products (see Section 8.1), including GenStar MPPT controllers (natively) and other devices, when equipped with the EMC-1 gateway device, can also provide access to polling of real-time operating data via SNMP v2c.

Data can be monitored using 3rd-party Network Management Software (NMS) and supported platforms can be recommended by Morningstar upon request.

A list of parameters and addresses, along with the industry-standard Management Information Base (.mib) files, for each device are available for download from the EMC-1 product page on our website (<https://www.morningstarcorp.com/products/ethernet-meterbus-converter/>).

For automatic parsing of the MIB file, as is supported by some NMSs, it is important that the following files be uploaded together in order for the device to be recognized:

- [DEVICE NAME].mib
- MORNINGSTAR.mib
- EMC-1.mib (when using the EMC-1)

Additional 'device' MIBs can be added as necessary. **NOTE:** SNMP browsers such as iReasoning's, "MIB Browser" support this functionality and can be downloaded online free of charge.

Data can also be retrieved using the following SNMP commands:

GET

Method used by the SNMP manager to request information from a SNMP agent on a specific OID.

GET NEXT

Method used by SNMP manager to work through an ordered list of OIDs according to the standard MIB hierarchy.

GET BULK

A sequence of GetNext requests, allowing a large segment of the MIB hierarchy to be queried by the SNMP manager from a managed device.

RESPONSE

Used by the SNMP agent to deliver requested information. Also acts as an acknowledgment.

While the GenStar MPPT and EMC-1 do not support asynchronous SNMP Traps, an SNMP browser running on the Network Management System (NMS)/Manager computer can provide effective alert notification options. Using a polling frequency and conditional logic rules found in the NMS, the browser can be configured to alert the user of abnormalities in system performance.

The GenStar MPPT controller also supports SET commands for certain writable EEPROM settings as defined in the control's MIB file. However, SET commands are not supported with the EMC-1. As is typically used with the community-based authentication model, there are (3) writable fields in the EMC-1: sysContact, sysName, and sysLocation. These can be set to arbitrary values, but will be reset when the device is powered off. If additional settings must be modified, use LiveView 2.0 with the GenStar MPPT controller or our MSView software with the EMC devices to do so accordingly. Refer to Section 5.0 for further information.

8.3 SNMP Traps (TriStar MPPT built-in Ethernet only)



NOTE: The default IP port assignment for the SNMP Trap Receiver is 162

Asynchronous SNMP traps are configured and behave similarly to e-mail/SMS alerts. An SNMP trap receiver can be specified in MSView™. When a specified condition is met (alarm, fault, custom event), a trap is sent to the receiver, notifying it of the condition.

As with e-mail and SMS alerts, the Ethernet equipped TS-MPPT controllers may have traps triggered by conditions of other MODBUS™ enabled units on the network (EIA-485).

8.4 E-mail Alerts (TriStar MPPT built-in Ethernet only)

E-mail forwarding is supported by Ethernet-equipped TS-MPPT controllers.

E-mail alerts can be configured from MSView™. You will be prompted to enter the outgoing SMTP server address and username/password. **NOTE:** Most forms of webmail (Google, Yahoo, etc) are not supported as the outgoing SMTP server; SSL (Secure Sockets Layer) is also not supported. Enter the recipient's e-mail address and proceed through the steps to set your specific alerts.

If the Ethernet equipped unit is on a MODBUS™ network (Morningstar products or otherwise), you can configure the alert to be triggered by an event on another network device. You must know the Modbus™ ID address of the device you want to monitor for the alert. For example, an Ethernet equipped TriStar MPPT may be on an EIA-485 network with three other Morningstar controllers, and two MODBUS™ enabled PLCs. The TS-MPPT can be configured to monitor the state of a MODBUS™ variable available to any of the other five devices. When a specified condition of this MODBUS™ variable is present, the TS-MPPT will generate an e-mail alert (or SMS/SNMP trap), and deliver it to the destination computer.

Refer to the TS-MPPT product manual for detailed information on how to configure e-mail alerts.

8.5 SMS Alerts - Text Messages (TriStar MPPT built-in Ethernet only)

SMS Text alerts can be sent by Ethernet-equipped TS-MPPT controllers.

SMS alerts can be configured from MSView™. Proceed to enter the outgoing SMTP server address and username/password. **NOTE:** Most forms of webmail (Google, Yahoo, etc) are not supported as the outgoing SMTP server: SSL (Secure Sockets Layer) is also not supported This step will be the same as if you were configuring an e-mail alert.

In the recipient's e-mail address field, you will need to enter the cell phone @ the cell phone carrier's SMS Gateway (i.e. 8885553333@vtext.com). Essentially you will be sending an e-mail to the recipient's cell phone provider. The provider will then translate the e-mail into SMS format and deliver it to the recipient's cell phone as a text message.

Contact the cell phone provider or perform an Internet search (several web sites exist listing these SMS Gateways) to determine the proper gateway address.

Refer to the TS-MPPT product manual for detailed information on how to configure SMS-text alerts.

9.0 Data Logging

9.1 Overview

Data logging is used to gather system relevant data and store it for later retrieval. Several Morningstar products will perform basic data logging to onboard memory. Please refer to specific product documentation for information on the internal logging performed by these units.

For more advanced logging, (i.e. specifying what data values to be logged, and at what interval) the use of either MSView™, a custom designed MODBUS™ application, or a 3rd party data acquisition service is necessary.

9.2 MSView™

The MSView™ software has the capability of performing high-resolution data logging for any number of variables available in the system. Logging intervals are custom defined by the user and can be specified down to a minimum of one second (meaning data is collected at a maximum rate of once per second).

While logging, MSView™ continuously saves the log file in .csv (comma separated values) format. This very common format is compatible with nearly all spreadsheet and database programs.

If you are using a controller with the capability of logging to onboard memory, MSView™ will extract this data from the controller every time you establish a connection to it.

9.3 LiveView 2.0 Webpage with GenStar MPPT

Internally logged data from the GenStar MPPT controller can be viewed in the History Tab in LiveView 2.0. This includes daily values, event logs and counters.

9.4 MODBUS™ Application

Morningstar controllers use the MODBUS™ protocol to communicate with 3rd party hardware, such as PCs and PLCs. A programming savvy user can create applications which will talk to Morningstar controllers using MODBUS™ and retrieve system information from the unit.

Morningstar products capable of communications with a 3rd party device have corresponding MODBUS™ specifications posted on the Morningstar web site. These specifications will provide a brief overview of the protocol, the functions supported, and data register locations for the model you are using.

9.5 Data Acquisition Service

Some companies provide data collection services for your renewable energy system. All the interfacing, programming, and setup are done by the service provider. Usually, the service provider collects data and displays it on a secure web site to be accessed at the customer's convenience. Data can often be converted to a graphical format, making it easier to understand for customers without a technical background.

Because the service provider handles all the communication, connections and technical issues, this means of data collection can be both professional and cost effective. Contact a data service provider for more information.

10.0 Network Security

General

Morningstar controllers/inverters do not contain any local security features or protections. The user is responsible for security through network configuration and settings. There will be no login or password required to communicate with the controller/inverter. If your system has Internet access, use of a firewall is highly recommended to prevent unauthorized users from accessing the controller.

Basic Security

If your Morningstar product will be connected to the Internet, it is highly advised that it is protected behind the firewall of another device, such as a router. Linksys™ brand routers are a cost effective way to provide a moderate amount of Internet security (if configured properly).

Ethernet equipped Morningstar products and the EMC-1 have an Ethernet Security DIP switch setting to allow/disable write commands to the unit's internal memory. (i.e. TSMPPPT - DIP Switch #8; EMC-1 DIP Switch #1) This a safety feature to prevent unintended changes to custom settings, but it is not a replacement for proper network security. Never connect units to an open or unprotected network.



NOTE: Adjustments to network settings and custom charging setpoints are always enabled via RS-232 or EIA-485. The Ethernet Security switch only enables/disables remote configuration via TCP/IP.



CAUTION: Risk of Tampering
The Ethernet Security settings switch is NOT a replacement for network security. A network firewall should be used.



CAUTION: Risk of Tampering
The Ethernet Security settings switch does not block write commands to devices bridged via EIA-485.

High-Security Applications

Applications with tighter security needs will require more advanced routers or other equipment. Wireless applications are an example; wireless transmission is much easier to intercept than is wired transmission. To reduce the risks of sending sensitive information wirelessly, data encryption in conjunction with a firewall should be used.



Figure 47. Digi TransPort Cellular Modem Family

For wireless cellular connections, the Digi TransPort Cellular Modem family provides enhanced security features for enterprise-class applications. (Shown above.)

11.0 Troubleshooting & Misc.

Basic RS-232 Serial Communication Problems

If you are having problems communicating with a Morningstar product while using a serial to serial (or serial to RJ-11) connection:

- Make sure the device is powered with a battery or power supply. The device cannot communicate without power.
- Verify that the serial cable is not a Null Modem or crossover cable.
- Verify that no other programs or managers are attempting to use the same serial port.
- Check to make sure that COM port settings are correct. (Section 5.3.1)
- If using the controller's Ethernet connection as well, remove the Ethernet cable.
- Check the serial cable for continuity using a multimeter. The cable should have continuity from Pin1<->Pin1, Pin2<->Pin2, etc. If possible, try another cable.
- Shut down and restart PC. Try to reconnect.
- Try another PC.

Serial Port Power with 3rd Party Devices

The local DB-9 serial ports on all Morningstar products are opto-isolated from the rest of the unit. Therefore, power must be applied to the port via the serial cable connection. PC serial ports provide this power on the proper pins without modification, however, other products (such as Ethernet to serial converters, cellular modems, and wireless radios) may not provide proper power.

When choosing equipment that will connect via RS-232 to your Morningstar unit, you should know what port power is needed. Figure 48 is a basic pin diagram of a Morningstar DB-9 port:

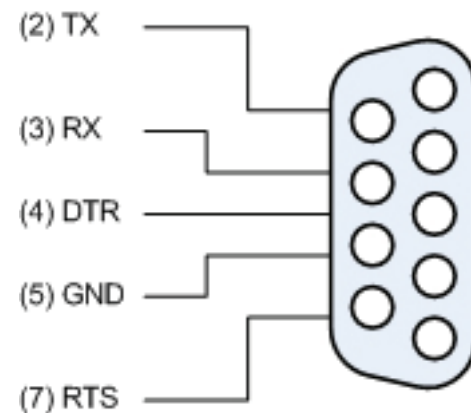

Figure 48. Morningstar DB-9 serial port pinout.

Power must be applied as follows:

- + Power must be asserted on the DTR and/or RTS pins
- Power must be asserted on the RTS and/or RX pins

Modifications can be made to your equipment (or RS-232 cable, but this is usually more difficult) so that the correct power is delivered to the Morningstar unit. Internally wiring several pins is usually all that is needed, but there is some equipment that does not provide negative (-) power at all, on any pin. These products cannot be modified to communicate with Morningstar units via RS-232.

NOTE: The TriStar MPPT has pins 4 and 6 internally connected, and pins 7 and 8 internally connected.

USB to Serial Problems

Where applicable Morningstar's UMC-1 USB MeterBus™ Adapter is the simplest solution for USB connections. Download the latest USB driver on our web site: www.morningstarcorp.com/support

Be sure you have read Subsection 5.3.1 on Establishing A Connection with your morningstar device. A common problem is the use of a Virtual Com Port when using a USB to Serial connection. This Subsection should rectify any VCOM problems that may exist.

If you are still having problems:

There have been reports that some USB to Serial adapters do not work with Morningstar products. This is most often because the adapter output voltage is below the RS-232 electrical specification. If the adapter does not output a high enough voltage, there is little the user can do to remedy the situation aside from purchasing a new adapter with the proper output voltage levels. **The Tripp Lite U209-000-R adapter described in Subsection 2.2.12 has been verified to work with all Morningstar products.**

NOTE: RS-232 line boosters are available which will amplify the signal voltage to the proper RS-232 specifications. These can be found online or in most electronics stores

Also, the number of USB devices connected to your PC may have an effect on communication with your Morningstar controller/inverter. More USB devices connected to your PC, especially through a USB hub, the greater the likelihood of timing problems on the bus. Because the MOD-BUS™ protocol used to communicate between a PC and controller/inverter is very timing-dependent, timing problems can cripple communication capabilities. Unplug some of your other USB devices and attempt a connection again.

Connection Distance Limitations

The following table outlines the various maximum wire run distances between two devices using the interfaces described in the rest of this manual. Different protocols have different timing and

attenuation requirements, therefore, the following figures are simply a guideline as many factors will affect them. **Remember:** In general, the shorter the wiring, the less attenuation and/or timing problems will occur.

Interface	Standard Maximum Distance
RJ-11 MeterBus	30 meters
RS-232	15 meters
RS-485	1.2 kilometers
USB	5 meters
RJ-45 Ethernet	100 meters

Table 5. Standard Cable Interface Max. Distances

Several devices can be used to increase these lengths. Active boosting USB cables, Ethernet switches and RS-232 line boosters can extend the length of their respective communication lines.

Morningstar Network LED Indicators

Meter Hub LEDs

Status LED	LED State	
	ON (green)	OFF
Port B	Power to Hub / correct network connection	No power to Hub. Refer to Table 2 in sub-section 3.2.2 for a list of devices which will supply power
Ports 1-4	Power to port / correct network connection	No devices connected to port / device connected does not supply power / wiring error or broken network cable

Table 6. Meter Hub LED Indicator(s) States

MSC Status LED

Status LED	Indication	Notes
Off	No bus power or reversed polarity	Check bus power and polarity
Green	Power OK, No data on network	Wiring OK, Ready for data
Green-red sequencing	Data on network	Network OK
Orange	Data Error	Power down & try again

Table 7. MSC Status LED Indicator States

UMC-1 Status LED

Status LED	Indication	Notes
Off	No connection to controller	Check bus power and polarity
Green	Connection OK, No activity	Wiring OK, Ready for data
Orange	Communication activity	Network OK

Table 8. UMC-1 Status LED Indicator States

RSC-1 Status LED

Status LED	Indication	Notes
Off	No bus power or reversed polarity	Check bus power and polarity
Green	Power OK, No data on network	Wiring OK, Ready for data
Green-red sequencing	Data on network	Network OK
Orange	Reversed A & B data lines	Check network wiring

Table 9. RSC-1 Status LED Indicator States

MRC-1 Status LEDs

Status LEDs	Indication	Notes
Off	No bus power or reversed polarity	Check bus power and polarity
Green	Power OK, No data on network	Power OK, ready for data
Green-amber sequencing	Data on network	Network OK
Amber	Reversed A & B data lines	Check network wiring

Table 10. MRC-1 LED Indicator States

Local Ethernet Jack Status LEDs

Condition	Green LED	Yellow LED
Network Connection OK	ON	OFF
Network Activity	ON	Blinking
Error	OFF	ON

Table 11. Ethernet Jack Status LED Indicator States

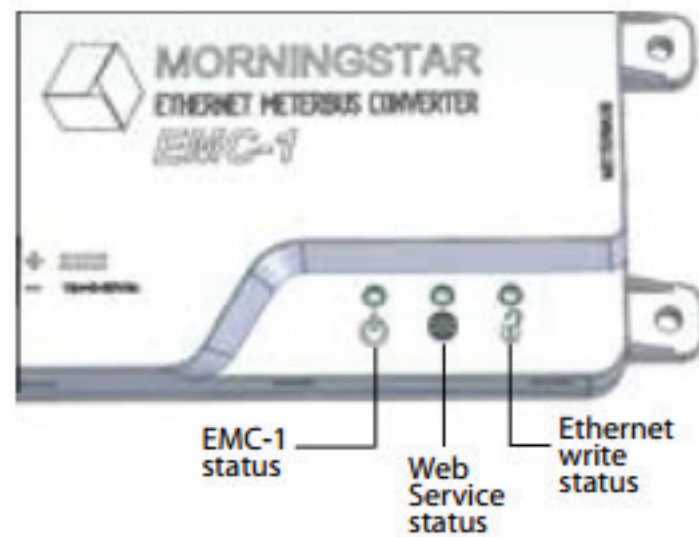

Figure 49. Morningstar EMC-1 LED Indicators

Status LED flash	green
LEDs ON for 3 seconds	green + green + green

Table 12a. EMC-1 Startup Indication

Condition	Green LED	Yellow LED
Network Connection OK	ON	OFF
Network Activity	ON	Blinking
Error	OFF	ON

Table 12b. Ethernet Jack Indications

Status LED	Indication
Flashing green: 1 every sec	Searching for Morningstar Device
Solid green	Morningstar Device found, communicating
Solid red	No valid Morningstar Devices found
Flashing red - green: 1 every sec	Morningstar Device found, unknown device ID - update EMC-1 firmware
Flashing green: 3 every sec	Firmware upgrade or downgrade in progress. Power should not be removed while in this state.
Flashing red: 1 every 2 sec	Internal fault condition

Table 12c. EMC-1 Status LEDs (green and red)

(future) Web Service OFF (DIP 2 Off)	Broadcasts disabled
(future) Web Service ON (DIP 2 ON)	Broadcasts enabled
Flashing green - 1 every 2 secs	Searching for server / establishing connection
Solid green	Connection made / broadcasting
Solid red	Cannot connect to server
Flashing red	TBD
Flashing red - green: 1 every 2 sec	Invalid log-in credentials* (connected to server)

* Log-in and/or server registration error

Table 12d. Web Service LEDs (green and red)

DIP 1 OFF (green OFF)	Ethernet writes disabled
DIP 1 ON (green ON)	Ethernet writes enabled

Table 12e. Ethernet Write LED (green)

Using MOXA MGate Series Ethernet to Serial MODBUS™ Converters

Some minor adjustments need to be made to the MOXA™ MGate™ device before it is able to communicate properly with a non-TSMPPT* controller. Modification to the handshake lines needs to be as follows:

- Pins 4(DTR) and 6(DSR) must be wired together.
- Pins 7(RTS) and 8(CTS) must be wired together.
- In the MOXA™ configuration manager, enable flow control DTR/DSR.

*If using the MGate™ with a TSMPPT, no adjustment to the device is necessary.

These changes are most easily made by removing the cover of the MOXA™ device and soldering the pins of the serial port directly. Another way to achieve the same effect is to make a custom serial cable which introduces the proper connections between the devices.

Using a straight-through serial cable to connect the MOXA™ MGate™ to the non-TSMPPT unit, the wiring should be as follows:

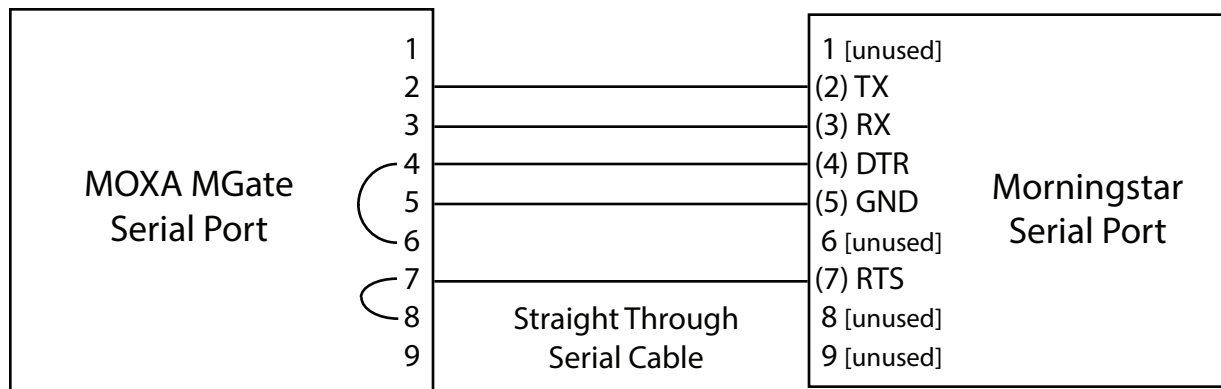

Figure 50. MOXA MGate pin adjustment.

The Morningstar **EMC-1 Ethernet MeterBus™ Converter** is highly recommended since it eliminates the need for these adjustments.

EIA-485 Bridging Notes

- Controllers with EIA-485 bridging capability will bridge **all** MODBUS TCP™ communications arriving from the Ethernet port to the EIA-485 network.
- Bridging must be enabled for the TS-MPPT controller to send out e-mail, SMS, or SNMP traps triggered by the state of a device elsewhere on the network.
- With bridging enabled, the DB-9 RS-232 connection on the controller cannot be used. EIA-485 and RS-232 ports share the same internal hardware and communication errors will result.

Trendnet TE100-S5 Ethernet Switch Compatibility

The TS-MPPT-60 Ethernet interface will not work properly with the Trendnet TE100-S5 Ethernet switches without a wiring modification. Trendnet switches have their Tx+ and Tx- lines, and their Rx+ and Rx- lines, swapped. These switches may work with a PC because most computers support auto-polarity (automatic adjustment to this swapped polarity).

The TriStar MPPT Ethernet hardware does not support auto-polarity. This means that a wiring modification must be made if you would like to use the TSMPPT with the Trendnet switch.

One end of the Ethernet cable should have the following pinout:

T-568B		
Pin	Color	Pin Name
1	Orange Stripe	Tx+
2	Orange	Tx-
3	Green Stripe	Rx+
4	Blue	
5	Blue Stripe	
6	Green	Rx-
7	Brown Stripe	
8	Brown	

The other end should have this pinout:

T-568B		
Pin	Color	Pin Name
1	Orange	Tx-
2	Orange Stripe	Tx+
3	Green	Rx-
4	Blue	
5	Blue Stripe	
6	Green Stripe	Rx+
7	Brown Stripe	
8	Brown	



NOTE: This wiring modification will be necessary when using the TriStar MPPT with any Ethernet switches having swapped Tx+/- and Rx+/- lines.

Please visit our **Tech Notes** page on www.morningstarcorp.com for regularly updated troubleshooting tips and tricks.

Appendix I - TSMPT & EMC-1 Networking

I. Introduction

GenStar MPPT controllers and all 60A models of the TriStar MPPT family of charge controllers have Ethernet ports and web features. These models can be connected to your home network so that operating information can be displayed on any computer on the network.

The EMC-1 Ethernet MeterBus™ Converter also provides Ethernet connectivity for all Morningstar devices that include a MeterBus™ port. The information in Appendix I will apply to using the EMC-1 with MSView™ or LiveView.

This Appendix covers the steps required to connect your ethernet-enabled GenStar MPPT controller or EMC-1 connected device to your home network. Instructions are also included to configure your network router for remote access for these devices via the Internet. For users that only need to access the Morningstar devices of their system from within their home network, the Remote Access steps are not required. Only set up remote access if you would like to view system performance on a computer or other network device outside of your home network via the Internet.

II. Connect to Local Area Network (LAN)

The following section will guide you through the process of connecting a GenStar MPPT controller, TriStar MPPT controller or EMC-1 connected device to a home/business local network.

Getting Started

The GenStar MPPT, TriStar MPPT and EMC-1 were designed for easy setup on a home or business network through DHCP. DHCP is a service that automatically assigns a network configuration to a computer or device that appears on your network. The vast majority of residential and business network routers support DHCP and the service is usually turned on by default. Since Morningstar products have DHCP enabled by default, the network settings will be automatically assigned when connected. If you are confident that your Router has DHCP you might want to proceed to the HTML or MSView™ Ethernet connection instructions.

How can I tell if DHCP is enabled on my network?

If you have residential or business DSL, Cable, Fiber, or satellite Internet service and the network router was provided by the Internet provider, chances are really good that DHCP is already enabled. Just to be sure, you can go to any computer on your network and check its network settings.

Obtain info using a Windows PC

- Click the start menu button
- Choose the **Run...** menu item

Type **cmd** in the Open text field and click OK

At the prompt type **ipconfig /all** and hit enter. (note: there is a space between the “g” and “/”)

Network information similar to the screenshot below will be displayed

```
Windows IP Configuration

Host Name . . . . . : [REDACTED]
Primary Dns Suffix . . . . . : [REDACTED]
Node Type . . . . . : Unknown
IP Routing Enabled. . . . . : No
WINS Proxy Enabled. . . . . : No
DNS Suffix Search List. . . . . : [REDACTED]

Ethernet adapter Local Area Connection:

Connection-specific DNS Suffix . . . . . : 
Description . . . . . : Broadcom NetXtreme 57xx Gigabit Controller
Physical Address. . . . . : [REDACTED]
Dhcp Enabled. . . . . : Yes
Autoconfiguration Enabled . . . . . : Yes
IP Address. . . . . : 192.168.1.106
Subnet Mask . . . . . : 255.255.255.0
Default Gateway . . . . . : 192.168.1.1
DHCP Server . . . . . : 192.168.1.1
DNS Servers . . . . . : 192.168.1.99
                       151.196.0.38
Lease Obtained. . . . . : 05 Aug 2009 09:12 AM
Lease Expires . . . . . : 10 Aug 2009 09:12 AM
```

Figure 1. Windows PC ipconfig network info

In figure 1 above, the arrow points to the DHCP information. If your computer has DHCP enabled, then your network supports DHCP. Proceed to Step 1 in this section to connect a device to your network. If DHCP is disabled, you will need to configure the device with the correct network settings before proceeding. Follow the steps in V. Additional Info: Manual Network Configuration.

Obtain info using a Mac

- Click the Apple icon in the top left corner
- Select “System Preferences” from the menu
- Click the “Network” icon under *Network & Internet*
- Choose the network adapter to view the network info

What happens if my local network does not have DHCP enabled, but I connect the TriStar MPPT anyway?

The GenStar MPPT, TriStar MPPT or EMC-1 will search for a period of time for a valid DHCP server. If no server is found, it will default to the network settings listed in Part V. Additional Info.

The default network settings of the GenStar, TriStar MPPT and EMC-1 may or may not be compatible with your network. Since your network does not support DHCP, a network configuration could not be obtained. You will need to verify if the default settings are compatible with your network and modify them if necessary. See Part V. Additional Info - Manual Network Configuration.

HTML LAN Connection Using LiveView

Step 1

Connect a GenStar or TriStar MPPT to your network using an Ethernet cable or follow the instructions in section 2 of the EMC-1 manual. The unit must be powered up to communicate. Before proceeding to the next step, allow 5 minutes for the controller to connect to the network and acquire its network settings.

Step 2

Next, connect to the controller using a computer on the network.

Microsoft PC

1. Open a web browser
2. In the Internet address bar type the following: `http://tsmppptXXXXXXXX/test.html`

where “tsmppptXXXXXXXX” is the Morningstar Device’s NetBIOS name [product abbreviation + 8-digit serial no.]. See Table 4 in Section 7.1 for a list of Morningstar Product NetBIOS Abbreviations in Section 7.1. The serial number can be found on the label on the unit. The NetBIOS address is a permanent address that always points to the controller on the network.

3. When the connection is established the device’s LiveView HTML page will open. You may want to bookmark the page for future reference.



NOTE:

These steps may work for some Apple Mac and Linux operating systems that support NETBIOS.

MSView LAN Connection Using a Windows PC (TriStar MPPT and EMC-1)

Step 1

Connect the TriStar MPPT to your network using an Ethernet cable or follow the instructions in section 2 of the EMC-1 manual. The unit must be powered up to communicate. Before proceeding to the next step, allow 5 minutes for the controller to connect to the network and acquire its network settings.

Step 2

Next, connect to the controller using a computer on the network.

Microsoft PC

1. Open MSView™
2. Left click on “Devices”
3. Left click on “Search For Connected Devices” in the drop-down menu.
4. If the installation was successful you will see the device listed.

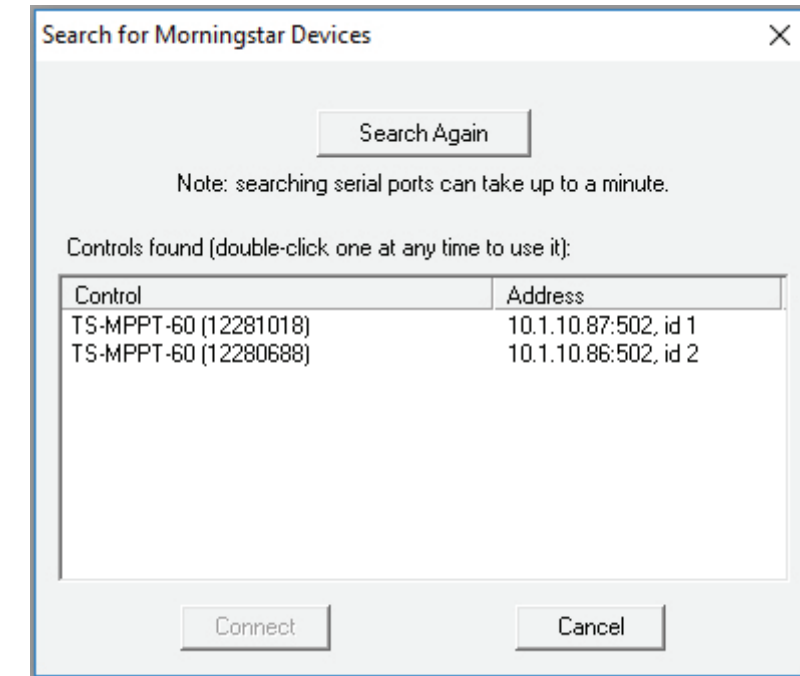

Figure 2a. MSView™ Search for Connected Devices Window

5. In figure 2a. above, notice that the controller model with the serial number is displayed on the left with the LAN IP Address and MODBUS™ ID Address displayed on the right.
6. Double left click on the device to connect to it or select and left click Connect.
7. Once connected you can right click on the device to view the properties Window.



NOTE:

MSView™ is a Windows-based software but there are various ways to run Windows programs on Apple Mac and Linux operating systems. A web search for “how to run windows programs on mac” will provide many options. Note that some of these options will be compatible with TCP/IP Ethernet connections but may not support USB or other Serial connections.

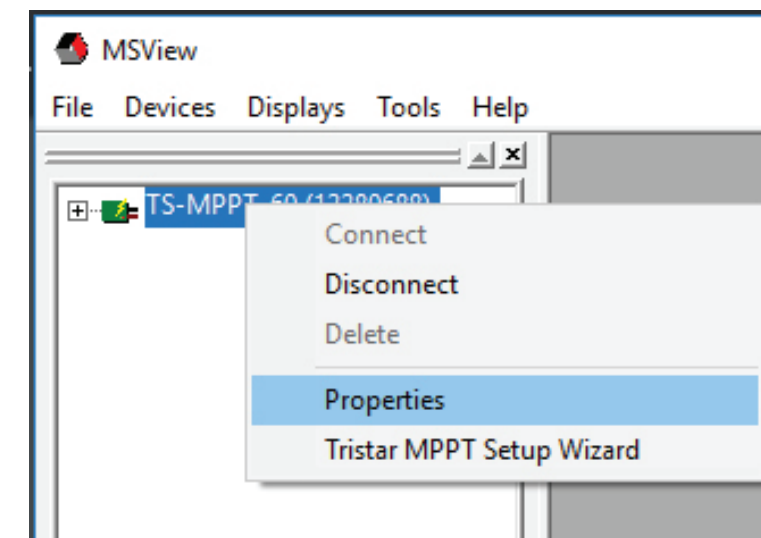

Figure 2b. MSView™ Device Properties Selection

FINAL NOTES

Congratulations! At this point the Morningstar device is successfully connected to your network. Following are notes about routinely connecting to a home or business network.

- Windows PC computers can always access a Morningstar device by using its NETBIOS name (tsmpptXXXXXXXX). See Table 4 in Section 7.1 for list of Morningstar Product NetBIOS Abbreviations in Section 7.1.
- Apple Mac computers may not support the use of NETBIOS names. You will have to use the discovery tool to find the controller on the network.
- The IP address assigned by DHCP may change periodically and is not a reliable way to connect to your controller. However, if you manually assign network settings, the IP address will never change.
- At this point, the Morningstar device cannot be accessed outside of your home or business network. See *Section III: Configure Remote Access* for details on how to connect to the TriStar MPPT from remote locations.

III. Configure Remote Access

Configure remote access to allow communication with a Morningstar device from any computer or device on the Internet. Once configured, the Internet connection provides the same type of access to data that is available on a local area network for MSView™, MODBUS™ or a web browser.



NOTE:

Before proceeding, make sure the Morningstar products is correctly configured and connected to your home/business network per the directions in Section II.



NOTE:

Because there are many different types and manufacturers of network routers, the exact steps required cannot be fully documented here. However, details are provided on where to get further information.



CAUTION:

All incoming requests addressed to controllers and devices that are connected (bridged) to the EIA-485 port on the GenStar or TriStar MPPT will be passed both READ and WRITE MODBUS™ requests without exception. Enabling Ethernet WRITES during commissioning for the GenStar MPPT, or setting switch #8 on the TriStar MPPT, only prevents WRITE requests to the local controller. For this reason, we do not recommend enabling remote access to systems with bridged EIA-485 networks unless extra network security measures are implemented.

Is this secure?

The vast majority of viruses, malware, scripts, etc are designed to exploit security flaws in major operating systems and their software. Malicious attackers wishing to do harm will only have access to the data from the Morningstar device. The device does not have an operating system or web browser to exploit. It only accepts and responds to properly structured MODBUS™ TCP requests. Both the TriStar MPPT and EMC-1 include setting switches that will only allow requests to read information and will not allow requests to write data. The GenStar MPPT provides the option to disable Ethernet writes during commissioning. In some cases energy usage information might be considered a security threat such as with smart home appliances. However, it is otherwise unlikely that this configuration poses a significant security risk.

It is also worth noting that the networking and charge controller functions of the GenStar and TriStar MPPT are separate and are executed by two (2) separate processors. If the network processor crashes for any reason, the charge controller functionality will continue unaffected. This, of course is also the case with the EMC-1 and the connected device.

Configure the Network Router and Morningstar Device

A router provides a gateway between the Internet and your private local network. A router is usually provided to DSL, cable, fiber, and satellite customers by their Internet service provider (ISP). The router connects to the incoming phone line, cable coax, or fiber line and provides one (1) or more Ethernet ports for your home/business computers.

Most network routers have a web interface for configuration. This interface is usually protected by password. If your router was supplied by your ISP (Cable, DSL, satellite company), they can provide you with the login/password needed to access the router configuration. If you purchased and installed your own router, the factory default password should be provided in the router documentation.

Step 1 - Retrieve the Current Morningstar Device Network Settings

- a. Open a web browser on any computer on your local network
- b. Open the LiveView web page for the device
- c. Click the “Network” link at the top of the LiveView page for the TriStar MPPT or EMC-1 device or navigate to the Settings tab at the top of the LiveView 2.0 for the GenStar MPPT
- d. Write down all the information in the Current Network Settings section
- e. Also note under the “Settings” section if “Obtain IP address from DHCP server” is selected.

Step 2 - Login to the network Router

- a. Open a web browser on any computer on your local network
- b. Enter the IP of the “Default Gateway” listed in the Morningstar device network settings
- c. When prompted enter the login/password information for the router
- d. Keep this browser window open since access to the router settings will be needed throughout these instructions

Step 3 - Program the Morningstar Device with Static Network Information

If the device is configured for DHCP, you will need to disable DHCP and specify your own static network settings. (* - see note) If a Static IP address is already assigned to the device and is compatible with your network, you can skip Step 3 and go straight to Step 4.

- a. Open the web browser that contains the router settings from Step 2
- b. Find the DHCP range (dynamic IP range) under the DHCP settings. It may look something like this:

	Dynamic IP Range
Range Start :	192 . 168 . 1 . 100
Range End :	192 . 168 . 1 . 149

- c. Pick an IP that lies *outside* of this range. For the example range above, 192.168.1.50 would be a good choice

- d. Browse back to the LiveView network settings page in the TriStar MPPT or EMC-1 device or navigate to the LiveView/ Setup/ Network page of the LiveView 2.0 for the GenStar MPPT
- e. In the Settings section, change the selection from “Obtain IP address from DHCP server” to “Use Static IP address”
- f. In the IP Address fields, enter the IP chosen in step c.
- g. Fill out the rest of the network settings with the info obtained in Step 1. (essentially, copy the info from the Current Settings section on the same page)
- h. Click the “Save” button to use the new settings

* **NOTE:** Some routers can assign a fixed IP address to devices that are configured for DHCP. If your router has this option then a fixed IP address can be assigned with the router interface.

Step 4 - Setup Port Forwarding

Next, set up port forwarding. Port forwarding commands the router to direct all incoming traffic from the Internet on a specific port to a computer or device inside your private network. In this case, you want to direct all incoming requests on port 502 directly to the connected device.

Additionally, you may also want to forward the Morningstar device’s port 80. This will allow viewing of LiveView pages from any computer on the Internet. This is not required, however.

There are many different router models so we cannot provide specific directions in this document for configuring port forwarding. However, the web site: <http://www.portforward.com> provides a comprehensive list of routers and instructions for forwarding ports. The forwarding information for all Morningstar devices follows:

To enable remote access to a Morningstar device using MSView™ or other 3rd party software

IP: Static IP assigned to the controller in Step 3f
 port: 502 (some routers ask for a range of ports, in this case specify 502 to 502)
 protocol: TCP

If you want to view LiveView web pages from any computer on the Internet, the following additional port must also be forwarded in addition to port 502.

IP: Static IP assigned to the controller in Step 3f
 port: 80 (some routers ask for a range of ports, in this case specify 80 to 80)
 protocol: TCP

Step 5 - Set up Dynamic DNS Service

Many ISPs allocate dynamic IP addresses to their customers. In plain English this means that the public address that uniquely identifies your home/business router on the Internet changes. This is equivalent to having your mailing address change randomly. The postal service can’t deliver your mail if they don’t know your address!

Your Internet Service Provider (ISP) can advise if you have a *static*, or a *dynamic*, IP address. If you have a static IP address, it will never change, and you can by-pass this section. If you have a dynamic IP address, a reliable way to find your router’s address is required. This will ensure a reliable connection to the TriStar MPPT controller.

The solution is to use Dynamic DNS Service (DDNS). DDNS maps a static Internet address to your home network’s dynamic IP. A client must be installed on a computer in your network which will automatically update the DDNS when your router’s public IP has changed.



NOTE: Many modern routers now support DDNS which eliminates the need to run a client on your home computer. If your router supports DDNS, it can be configured to automatically update the DDNS servers whenever the IP address changes. Check your router’s documentation or check the approved vendors list at <http://dyn.com/remote-access/>

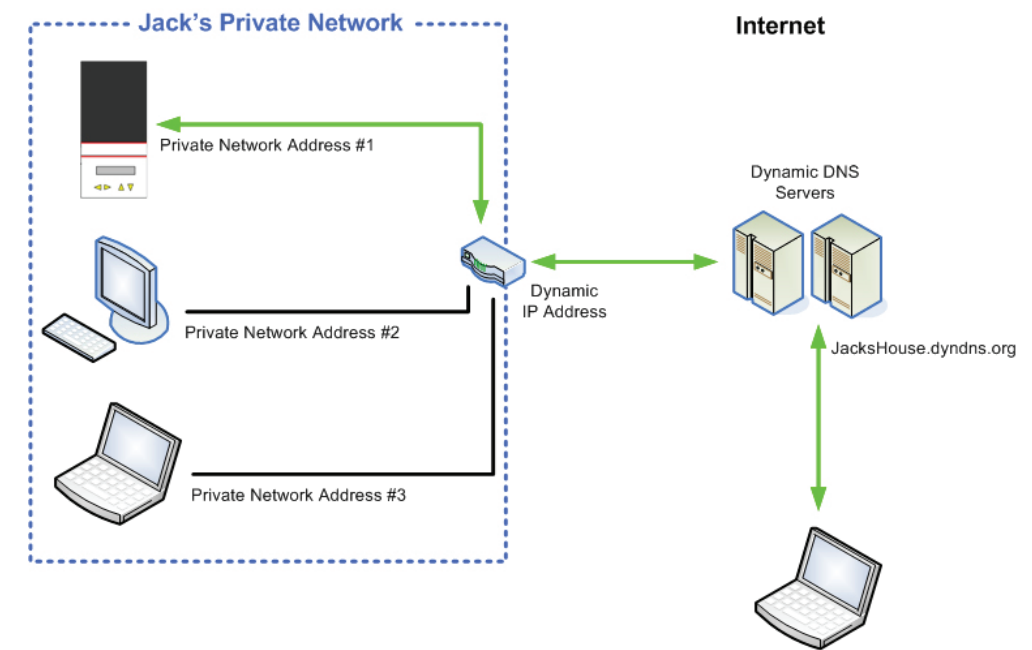

Figure 3. Dynamic DNS service

Figure 4, above, illustrates how DDNS works. Dynamic DNS servers are notified by a computer on Jack’s private network whenever the router IP changes. The address: *JacksHouse.dyndns.org* points to the DDNS servers which in turn forward the request to the latest IP address of Jack’s Private Network.

Who provides this service and how much does it cost?

We recommend using Dynamic DNS service provided by www.DynDNS.com. It is reliable and has a proven track record. However, there are other DDNS services that will work just as well. Detailed setup information is available on their web sites.

IV. Multi-Controller Networking Options

Two or More Morningstar Connected Devices

Whenever possible, network multiple Morningstar products using an Ethernet hub or router. This network scheme can result in the lowest cost and most control over each controller in the network. Morningstar devices that do not have Ethernet ports can be connected via EIA-485 (see the next section) or with the EMC-1. Be sure to set the Ethernet Security Settings Switch (switch #8 on the TS-MPPT, Switch #1 on the EMC-1 or with the GenStar local display setup menu) to disable writes if the Ethernet network is accessible via the internet.

GenStar MPPT and 60A TriStar MPPT Controller(s) + Other Morningstar Products

GenStar MPPT and 60A TriStar MPPT 60 controllers can be connected to other Morningstar products on a network using the built-in EIA-485 interface. The GenStar or TriStar MPPT 60 connects to a network router using the Ethernet port. All devices in the system are connected together on a EIA-485 bus. Incoming requests from the LAN or Internet that are addressed to devices on the network are bridged through the GenStar MPPT or TriStar MPPT 60 onto the EIA-485 bus. For products such as the Relay Driver that have a serial port, an EIA-485 adapter (model: RSC-1) can be used to connect to the EIA-485 bus as shown in Figure 4 below. Products that do not have a serial port require an additional MeterBus™ adapter (model: MSC) to convert the RJ-11 interface to serial.

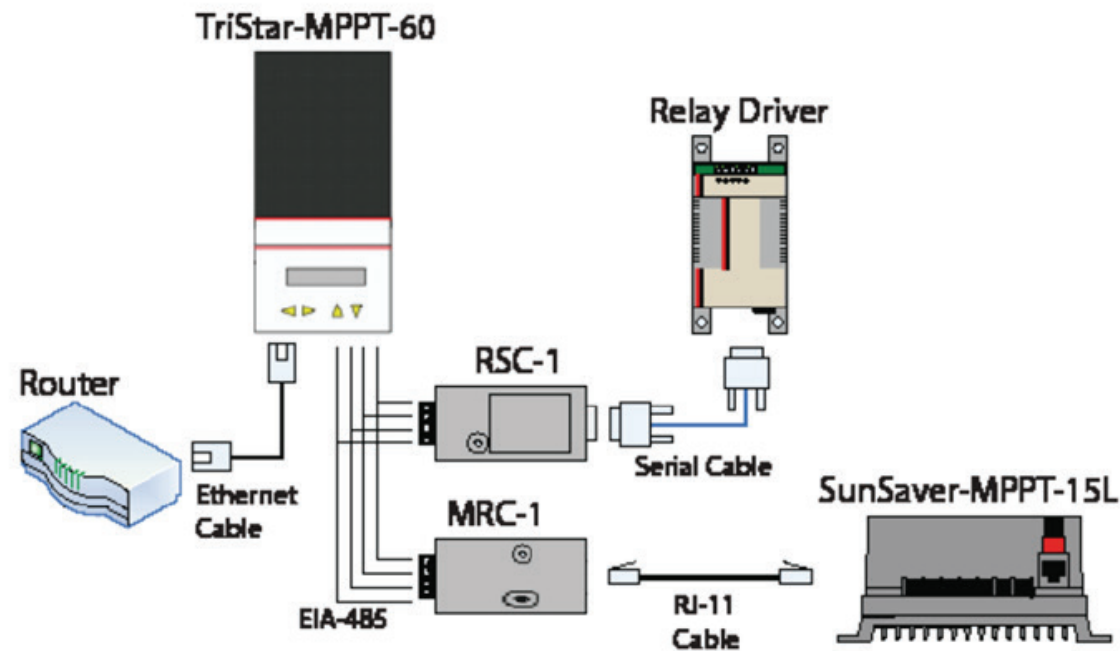

Figure 4. Networking Morningstar products that do not have Ethernet ports.

The EIA-485 bridging feature must be enabled in the network settings of the TriStar MPPT 60 controller as follows:

- Open the TriStar LiveView web page
- Click the “Network” link at the top

- Under the “Settings” section, check the box for the “Bridge Ethernet MODBUS™ requests to EIA-485 network” option.
- Click the “Save” button



NOTE:

The RSC-1 EIA-485 adapter requires power from the battery or DC-DC converter to power the bus. The RSC-1 can be powered directly from a 12V system battery. For 24 or 48V systems, a DC-DC power converter is required.



CAUTION:

All incoming requests addressed to controllers and devices that are connected (bridged) to the EIA-485 port on the GenStar or TriStar MPPT will be passed both READ and WRITE MODBUS™ requests without exception. Setting switch #8 on the TriStar MPPT only prevents WRITE requests to the local controller. For this reason, we do not recommend enabling Internet access to systems with bridged EIA-485 networks unless extra network security measures are implemented.

V. Additional Info

Manual Network Configuration

For networks that do not support DHCP, the Morningstar device must be manually configured. If there is more than one Morningstar Device in a system each device needs to have its own unique IP Address. Follow these steps to manually configure the network settings for the Morningstar device.

- Open a web browser on any computer on your local network. Enter the IP of the “Default Gateway” listed in the network settings information. Instructions for obtaining the network information are provided in the introductory notes in Section II.
- When prompted, enter the login/password information for the router. If you do not know this information, contact your ISP or consult the router documentation for the factory default login/password.
- If the Morningstar device is not compatible with the network you might be able to change the router’s local Gateway IP Address so it is compatible. Use the default gateway settings as indicated below. (92.168.1.1). See router documentation for instructions. Alternatively, connect with an Ethernet / Ethernet connection directly to a PC to change the IP Address to a compatible IP Address for the network (See Ethernet / Ethernet Connections below).
- Browse to the Network Setup screen in the GenStar MPPT LiveView 2.0 network settings page or to the network settings page in LiveView for the TriStar MPPT or EMC-1 connected device.
- In the TCP/IPv4 Settings section for the GenStar MPPT or the LiveView Network Settings for the TriStar MPPT or EMC-1 connected device, change the selection from “Obtain IP address from DHCP server” to “Use Static IP address”
- In the IP Address fields, enter the IP chosen in step c.
- Fill out the rest of the network settings with the info obtained in the introductory notes in Section II.

Ethernet/ Ethernet Direct PC Connections

Short-term Ethernet / Ethernet direct PC connections are commonly used for programming custom settings or for changing network settings of the Morningstar device so it can be connected to a network that does not support DHCP.

Connecting a PC directly to the Morningstar device with an Ethernet cable may require a crossover cable depending on the PC you are using. However, the Morningstar device may not have a compatible IP Address for the PC being connected. Therefore, if using a regular Ethernet cable be sure to check the IP settings on your PC as obtaining a crossover Ethernet cable might not be necessary.

- There are many instructions available on the Internet regarding how to determine your PC's IP address and how to reset it.
- Change the first three numbers of the IP address of the PC so it is compatible with the default IP Address. For 192.168.1.XXX but not identical to the device's IP Address of the device.

NOTE:

Another option is to change the IP address for the GenStar MPPT and 60A TriStar MPPT controllers to a compatible IP Address with the PC.

- Use the built-in display meter to change the IP address of the GenStar MPPT controller.
- Program the IP Address with MSView™ using a serial connection to change the IP address of the TriStar MPPT controller.

Default TriStar MPPT, GenStar MPPT and EMC-1 Settings

Port Assignments

Port 80:	HTTP Server
Port 502:	MODBUS™ via TCP/IP
Port 162 (TriStar MPPT):	SNMP Trap Receiver
Port 161 (GenStar MPPT and EMC-1):	SNMP Agent Receiver

Network Settings

Static IP:	192.168.1.253
Subnet Mask:	255.255.255.0
Default Gateway:	192.168.1.1.
Primary DNS	192.168.1.1
Secondary DNS	0.0.0.0
Bridged Ethernet MODBUS™ requests to the EIA-485 network are Disabled .	

Appendix II - Advanced System Example

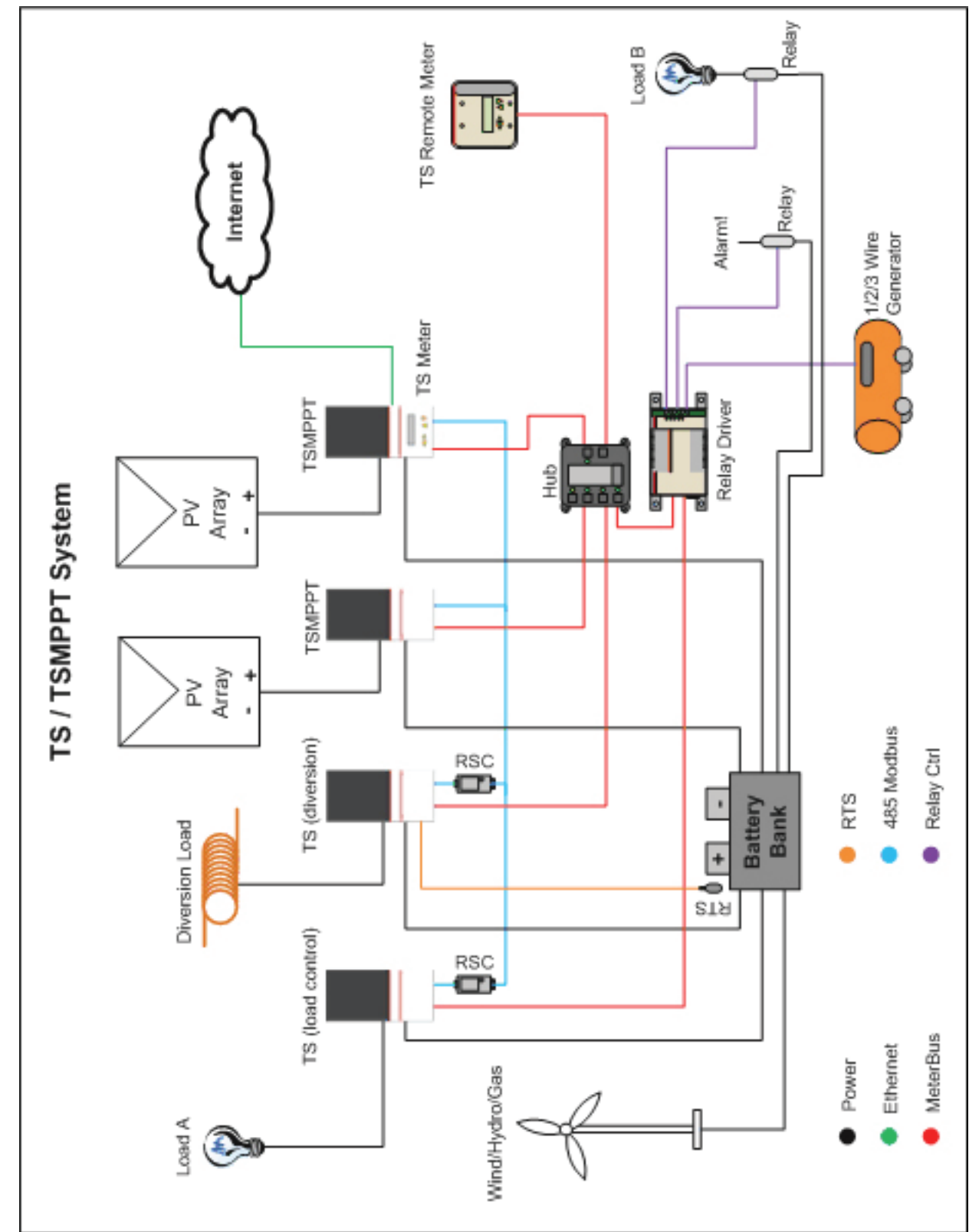

MS-002938 v3.7